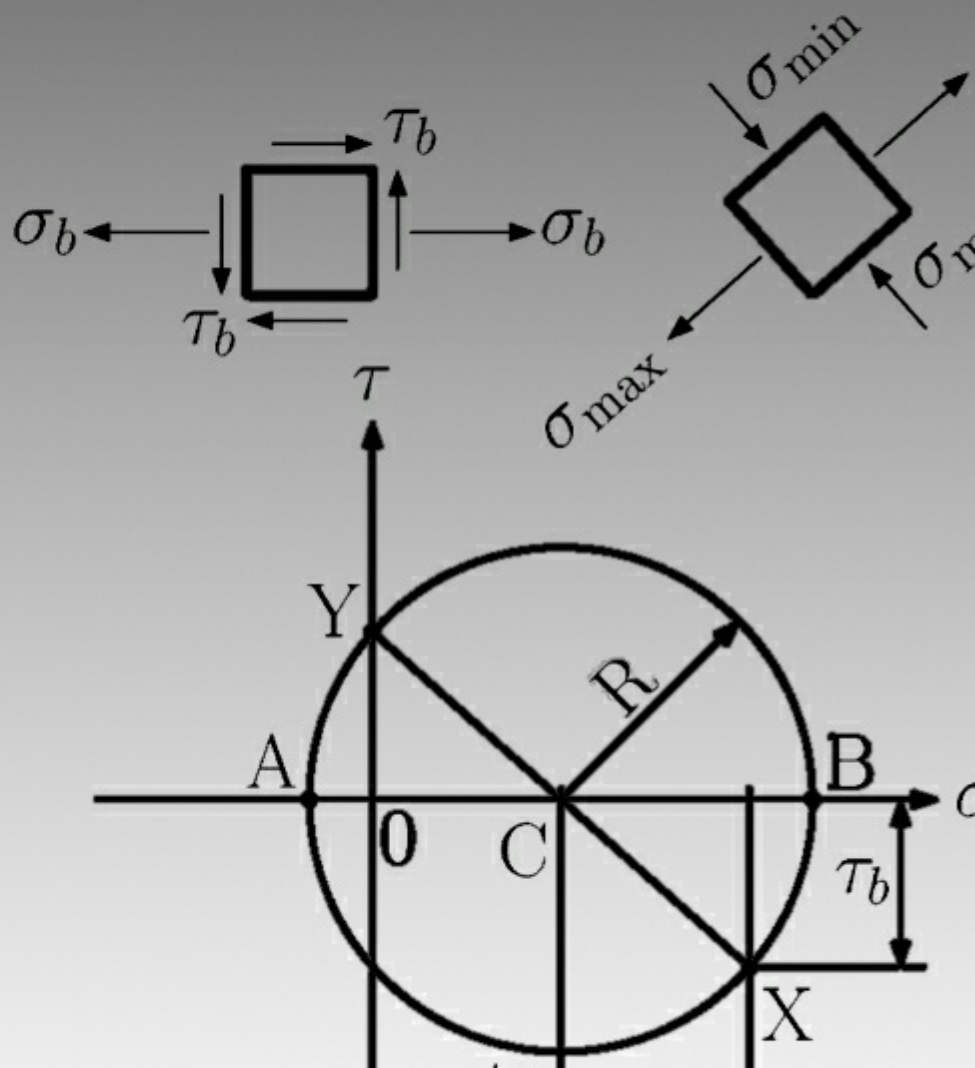


Branislav Hučko; Roland Jančo

Introduction to Mechanics of Materials: Part I



$$\frac{1}{8}wL^2 = \mathbf{M}_{\max}$$



Roland Jančo & Branislav Hučko

Introduction to Mechanics of Materials

Part I



Introduction to Mechanics of Materials: Part I

First Edition

© 2013 Roland Jančo, Branislav Hučko & bookboon.com

ISBN 978-87-403-0364-3

Contents

	List Of Symbols	8
	Preface	10
1	Introduction – Concept of stress	11
1.1	Introduction	11
1.2	A Short Review of the Methods of Statics	11
1.3	Definition of the Stresses in the Member of a Structure	16
1.4	Basic Stresses (Axial, Normal, Shearing and Bearing stress)	19
1.5	Application to the Analysis and Design of Simple Structures	24
1.6	Method of Problem Solution and Numerical Accuracy	25
1.7	Components of Stress under General Loading Conditions	27
1.8	Design Considerations and Factor of Safety	30
2	Stress and Strain – Axial Loading	32
2.1	Introduction	32
2.2	Normal Stress and Strain under Axial Loading	32



Discover the truth at www.deloitte.ca/careers

Deloitte.

© Deloitte & Touche LLP and affiliated entities.



Click on the ad to read more

2.3	Stress-Strain Diagram, Hooke's Law, and Modulus of Elasticity	35
2.4	Poisson's Ratio	38
2.5	Generalised Hooke's Law for Multiaxial Loading	40
2.6	Saint Venant's Principle	44
2.7	Deformations of Axially Loaded Members	47
2.8	Problems Involving Temperature Changes	51
2.9	Trusses	54
2.10	Examples, Solved and Unsolved Problems	55
3	Torsion	86
3.1	Introduction	86
3.2	Deformation in a Circular Shaft	88
3.3	Stress in the Elastic Region	94
3.4	Angle of Twist in the Elastic Region	97
3.5	Statically indeterminate Shafts	98
3.6	Design of Transmission Shafts	100
3.7	Torsion of Non-Circular Members	100
3.8	Thin-Walled hollow Members	106
3.9	Examples, Solved and Unsolved Problems	110

© 2013 Accenture. All rights reserved.

be > your degree

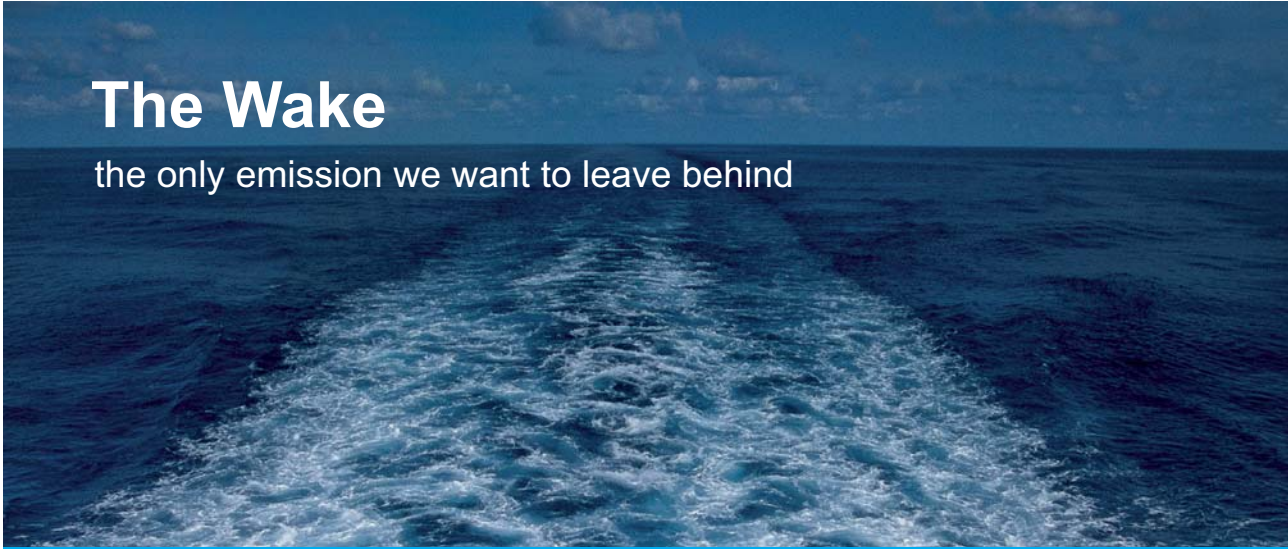
Bring your talent and passion to a global organization at the forefront of business, technology and innovation. Discover how great you can be.

Visit accenture.com/bookboon

Be greater than.
consulting | technology | outsourcing

accenture
High performance. Delivered.

4	Bending of Straight Beams	Part II
4.1	Introduction	Part II
4.2	Supports and Reactions	Part II
4.3	Bending Moment and Shear Force	Part II
4.4	Shear and Bending Moment Diagrams	Part II
4.5	Relations among Load, Shear, and the Bending Moment	Part II
4.6	Definition of Normal and Shearing Stresses	Part II
4.7	Design of Straight Prismatic Beams	Part II
4.8	Examples, Solved and Unsolved Problems	Part II
5	Deflection of Beams	Part II
5.1	Introduction	Part II
5.2	Integration method	Part II
5.3	Using a Singularity Function to Determine the Slope and Deflection of Beams	Part II
5.4	Castigliano's Theorem	Part II
5.5	Deflections by Castigliano's Theorem	Part II
5.6	Statically Indeterminate Beams	Part II
5.7	Examples, solved and unsolved problems	Part II



The Wake


the only emission we want to leave behind

Low-speed Engines Medium-speed Engines Turbochargers Propellers Propulsion Packages PrimeServ

The design of eco-friendly marine power and propulsion solutions is crucial for MAN Diesel & Turbo. Power competencies are offered with the world's largest engine programme – having outputs spanning from 450 to 87,220 kW per engine. Get up front! Find out more at www.mandieselturbo.com

Engineering the Future – since 1758.

MAN Diesel & Turbo



6	Columns	Part II
6.1	Introduction	Part II
6.2	Stability of Structures	Part II
6.3	Euler's formulas for Columns	Part II
6.4	Design of Columns under a Centric Load	Part II
6.5	Design of Columns under an Eccentric Load	Part II
6.6	Examples, solved and unsolved problems	Part II
	Appendix	135
A.1	Centroid and first moment of areas	135
A.2	Second moment, moment of areas	138
A.3	Parallel axis theorem	143
A.4	Product of Inertia, Principal Axes	151
A.5	Strain energy for simple loads	152
	References	159

SMS from your computer


...Sync'd with your Android phone & number

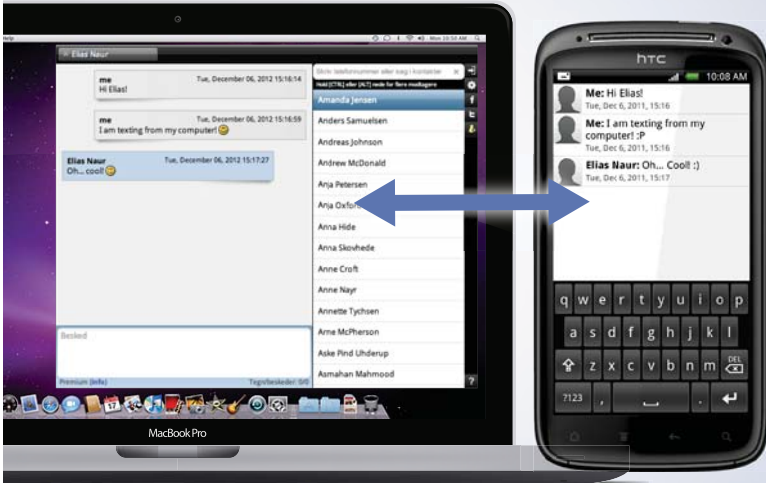
FREE
30 days trial!

Go to

BrowserTexting.com

and start texting from your computer!






List Of Symbols

A	Area
b	width
B.C.	buckling coefficient
D	diameter
E	modulus of elasticity, Young's modulus
f_s	shearing factor
F	external force
F.S.	factor of safety
G	modulus of rigidity
h	height
I_z, I_y	second moment, or moment of inertia, of the area A respect to the z or y axis
J_o	polar moment of inertia of the area A
L	length
DL	elongation of bar
M	bending moment, couple
N	normal or axial force
Q_z, Q_y	first moment of area with respect to the z or y axis
r_z	radius of gyration of area A with respect to the z axis
R	radius
R_i	reaction at point i
s	length of centreline
T	torque
t	thickness
ΔT	change of temperature
u	strain energy density
U	strain energy
V	volume
V	transversal force
w	uniform load
y(x)	deflection
A	area bounded by the centerline of wall cross-section area
α	coefficient of thermal expansion (in chapter 2)
α	parameter of rectangular cross-section in torsion
γ	shearing strain
ϵ	strain
ϕ	angle of twist
Θ_i	slope at point i
τ	shearing stress

τ_{all}	allowable shearing stress
σ	stress or normal stress
σ_{all}	allowable normal stress
σ_{max}	maximum normal stress
σ_{Mises}	von Mises stress
σ_{N}	normal or axial stress

Preface

This book presents a basic introductory course to the mechanics of materials for students of mechanical engineering. It gives students a good background for developing their ability to analyse given problems using fundamental approaches. The necessary prerequisites are the knowledge of mathematical analysis, physics of materials and statics since the subject is the synthesis of the above mentioned courses.

The book consists of six chapters and an appendix. Each chapter contains the fundamental theory and illustrative examples. At the end of each chapter the reader can find unsolved problems to practice their understanding of the discussed subject. The results of these problems are presented behind the unsolved problems.

Chapter 1 discusses the most important concepts of the mechanics of materials, the concept of stress. This concept is derived from the physics of materials. The nature and the properties of basic stresses, i.e. normal, shearing and bearing stresses; are presented too.

Chapter 2 deals with the stress and strain analyses of axially loaded members. The results are generalised into Hooke's law. Saint-Venant's principle explains the limits of applying this theory.

In chapter 3 we present the basic theory for members subjected to torsion. Firstly we discuss the torsion of circular members and subsequently, the torsion of non-circular members is analysed.

In chapter 4, the largest chapter, presents the theory of beams. The theory is limited to a member with at least one plane of symmetry and the applied loads are acting in this plane. We analyse stresses and strains in these types of beams.

Chapter 5 continues the theory of beams, focusing mainly on the deflection analysis. There are two principal methods presented in this chapter: the integration method and Castigliano's theorem.

Chapter 6 deals with the buckling of columns. In this chapter we introduce students to Euler's theory in order to be able to solve problems of stability in columns.

In closing, we greatly appreciate the fruitful discussions between our colleagues, namely prof. Pavel Élesztős, Dr. Michal Čekan. And also we would like to thank our reviewers' comments and suggestions.

Roland Jančo
Branislav Hučko

1 Introduction – Concept of stress

1.1 Introduction

The main objective of the mechanics of materials is to provide engineers with the tools, methods and technologies for

- *analysing* existing load-bearing structures;
- *designing* new structures.

Both of the above mentioned tasks require the analyses of *stresses* and *deformations*. In this chapter we will firstly discuss the stress.

1.2 A Short Review of the Methods of Statics

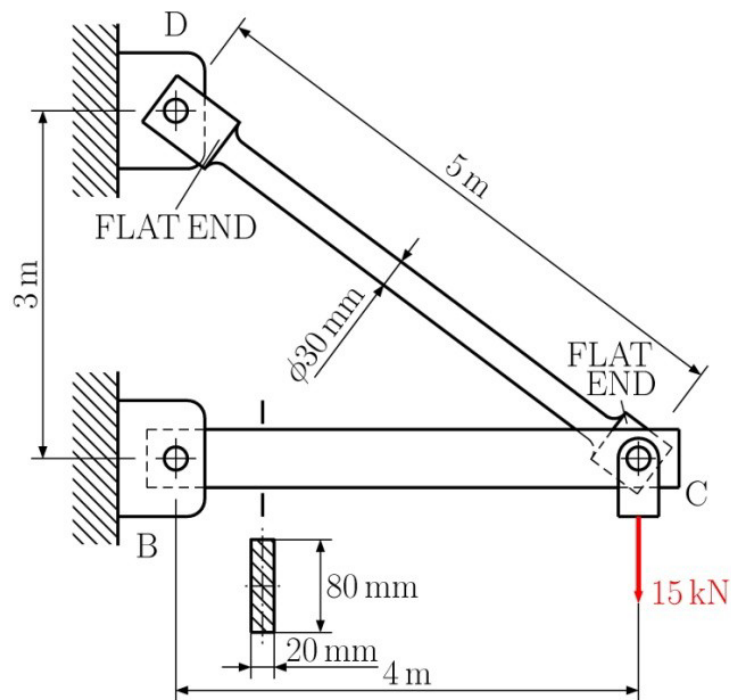


Fig. 1.1

Let us consider a simple truss structure, see Fig. 1.1. This structure was originally designed to carry a load of 15kN. It consists of two rods; *BC* and *CD*. The rod *CD* has a circular cross-section with a 30-mm diameter and the rod *BC* has a rectangular cross-section with the dimensions 20×80 mm. Both rods are connected by a pin at point *C* and are supported by pins and brackets at points *B* and *D*. Our task is to analyse the rod *CD* to obtain the answer to the question: is rod *CD* sufficient to carry the load? To find the answer we are going to apply the methods of statics. Firstly, we determine the corresponding load acting on the rod *CD*. For this purpose we apply the joint method for calculating axial forces in each rod at joint *C*, see Fig. 1.2. Thus we have the following equilibrium equations

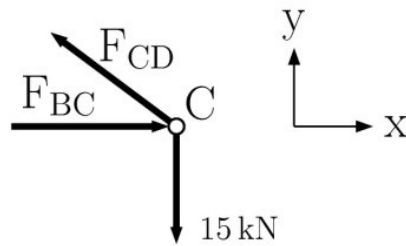


Fig. 1.2

$$\sum F_x = 0 \quad F_{BC} - F_{CD} \frac{4}{5} = 0$$

$$\sum F_y = 0 \quad F_{CD} \frac{3}{5} - 15 \text{ kN} = 0 \quad (1.1)$$

Solving the equations (1.1) we obtain the forces in each member: $F_{BC} = 20 \text{ kN}$, $F_{CD} = 25 \text{ kN}$. The force F_{BC} is compressive and the force F_{CD} is tensile. At this moment we are not able to make the decision about the safety design of rod CD .

Secondly, the safety of the rod BC depends mainly on the material used and its geometry. Therefore we need to make observations of processes inside of the material during loading.

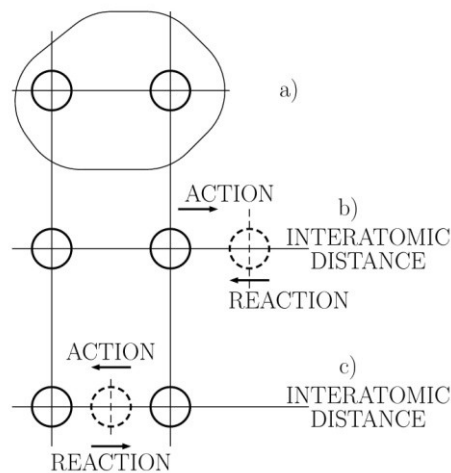


Fig. 1.3

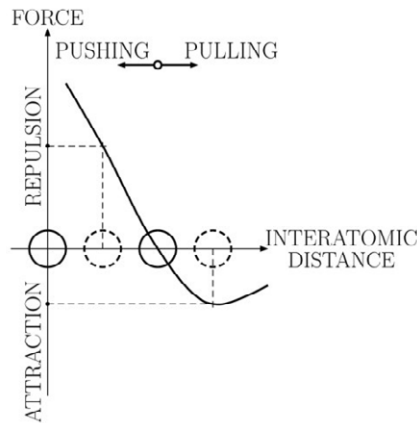


Fig. 1.4

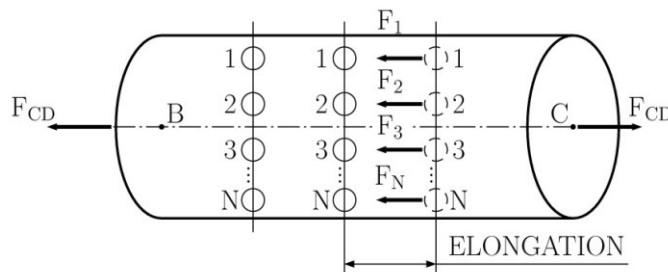


Fig. 1.5

**YOUR WORK AT TOMTOM WILL
BE TOUCHED BY MILLIONS.
AROUND THE WORLD. EVERYDAY.**

Join us now on www.TomTom.jobs

follow us on **LinkedIn**



#ACHIEVEMORE

TOMTOM 



Let us consider a crystalline mesh of rod material. By detaching two neighbour atoms from the crystalline mesh, we can make the following observation. The atoms are in an equilibrium state, see Fig. 1.3(a). Now we can pull out the right atom from its equilibrium position by applying external force, see Fig. 1.3(b). The applied force is the action force. Due to Newton’s first law a reaction force is pulling back on the atom to the original equilibrium. During loading, the atoms find a new equilibrium state. The action and the reaction are in equilibrium too. If we remove the applied force, the atom will go back to its initial position, see Fig. 1.3(a). If we push the right atom towards the left atom, we will observe a similar situation; see Fig. 1.3(c). Now we can build the well-known diagram from the physics of materials: internal force versus interatomic distance, see Fig. 1.4. From this diagram we can find the magnitudes of forces in corresponding cases. Now we can extend our observation to our rod *CD*. For simplicity let us draw two parallel layers of atoms inside the rod considered, see Fig. 1.5. After applying the force of the external load on *CD* we will observe the elongation of the rod. In other words, the interatomic distance between two neighbouring atoms will increase. Then due to Newton’s first law the internal reaction forces will result between two neighbouring atoms. Subsequently the rod will reach a new equilibrium. Thus we can write:

$$\sum_{i=1}^N F_i = F_{CD} \quad \text{or} \quad \sum \text{internal forces} = \text{external applied force} \quad (1.2)$$

The next task is to determine the internal forces. Considering the continuum approach we can replace equation (1.2) with the following one:

$$\text{Resultant of internal forces} = \text{external applied force} \quad (1.3)$$

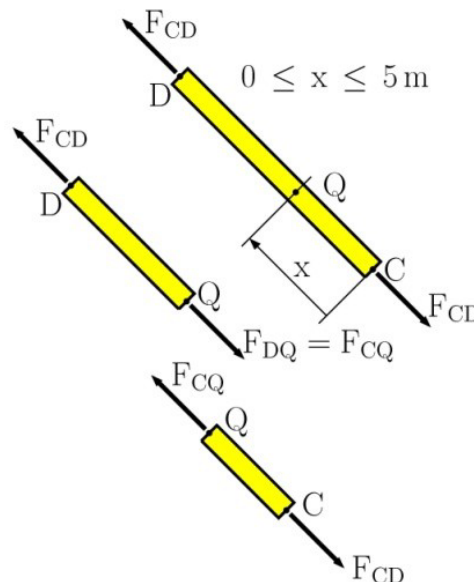


Fig. 1.6

The resultant can be determined by applying *the method of section*. Passing the section at some arbitrary point Q we get two portions of the rod: CQ and DQ, see Fig. 1.6. Since force $F_{CD} = 25 \text{ kN}$ must be applied at point Q for both portions to keep them in equilibrium, we can conclude that the resultant of internal forces of 100 kN is produced in the rod CD, when a load of 15kN is applied at C.

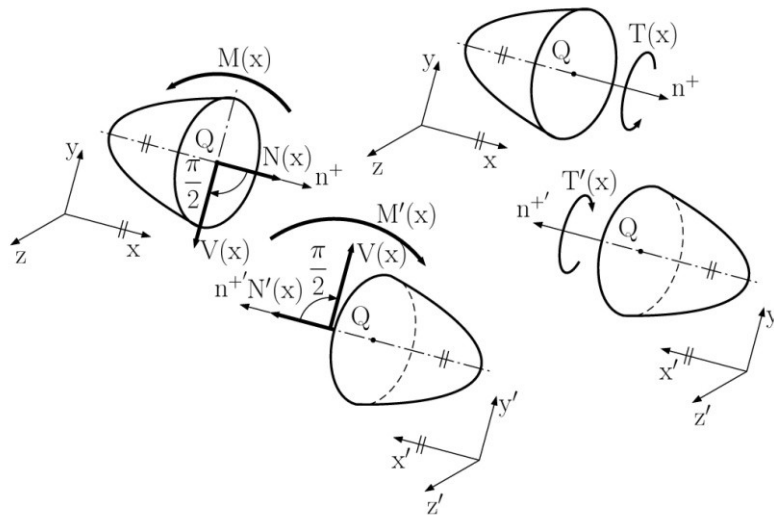


Fig. 1.7

The above mentioned method of section is a very helpful tool for determining all internal forces. Let us now consider the arbitrary body subjected to a load. Dividing the body into two portions at an arbitrary point Q, see Fig. 1.7, we can define the positive outgoing normal n^+ . *the normal force* $N_{(x)}$ is the force component in the direction of positive normal. The force component derived by turning the positive normal clockwise about $\frac{\pi}{2}$ at Q is known as *the shear force* $V_{(x)}$, the moment $M_{(x)}$ about the z-axis defines *the bending moment* (the positive orientation will be explain in Chapter 4). The moment $T_{(x)}$ defines *the torque* with a positive orientation according to the right-hand rule.

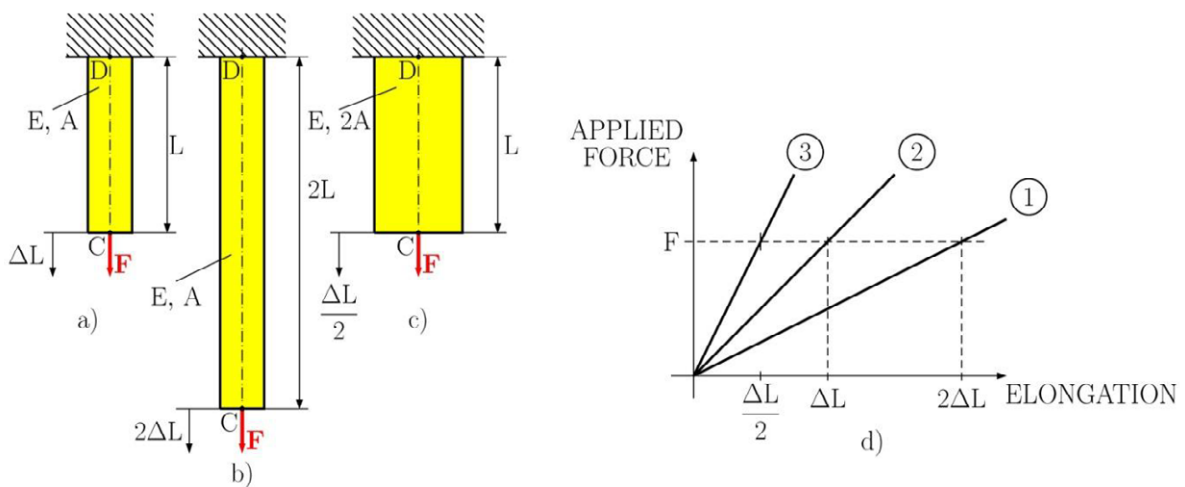


Fig. 1.8

For assessing the safety of rod CD we need to ask material scientists for the experimental data about the materials response. When our rod is subjected to tension, we can obtain the experimental data from a simple tensile test. Let us arrange the following experiments for the rod made of the same material. The output variables are the applied force and the elongation of the rod, i.e. the force vs. elongation diagram. The first test is done for the rod of length L , and cross-sectional area A , see Fig 1.8 (a). The output can be plotted in Fig 1.8 (d), seen as curve number 1. For the second test we now define the rod to have a length of $2L$ while all other parameters remain, see Fig. 1.8 (b). The result is represented by curve number 2, see Fig. 1.8 (d). It is only natural that the total elongation is doubled for the same load level. For the third test we keep the length parameter L but increase the cross-sectional area to $2A$. The result are represented by curve number 3, see Fig. 1.8 (d). The conclusion of these three experiments is that the load vs. elongation diagram is not as useful for designers as one would initially expect. The results are very sensitive to geometrical parameters of the samples. Therefore we need to exclude the geometrical sensitivity from experimental data.

1.3 Definition of the Stresses in the Member of a Structure

The results of the proceeding section represent the first necessary step in the design or analysing of structures. They do not tell us whether the structure can support the load safely or not. We can determine the distribution functions of internal forces along each member. Applying the method of section we can determine the resultant of all elementary internal forces acting on this section, see Fig. 1.9. The average intensity of the elementary force ΔN over the elementary area ΔA is defined as $\Delta N/\Delta A$. This ratio represents the internal force per unit area. Thus the intensity of internal force at any arbitrary point can be derived as

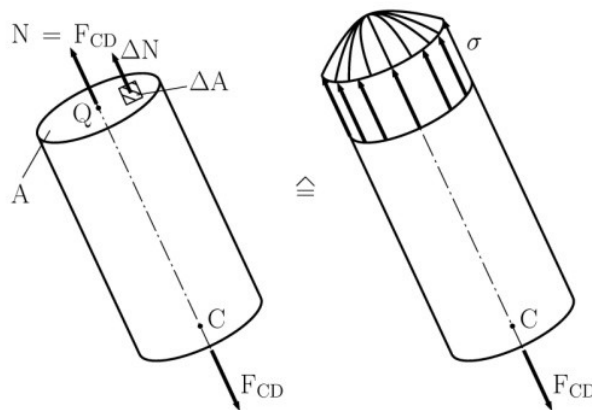


Fig. 1.9

$$intensity = \lim_{\Delta A \rightarrow 0} \frac{\Delta N}{\Delta A} = \frac{dN}{dA} \quad (1.4)$$

Whether or not the rod will break under the given load clearly depends upon the ability of the material to withstand the corresponding value, see the above mentioned definition, of the distributed internal forces. It is clear that this depends on the applied load F_{CD} , the cross-section area A and on the material of the rod considered.

The internal force per unit area, or the intensity of internal forces distributed over a given cross-sectional area, is called *stress*. The stress is denoted by the Greek letter sigma σ . The unit of stress is called the Pascal which has the value N/m^2 . Then we can rewrite equation (1.4) into

$$\sigma = \lim_{\Delta A \rightarrow 0} \frac{\Delta N}{\Delta A} = \frac{dN}{dA} \quad (1.5)$$

The positive sign indicates tensile stress in a member or that the member is in tension. The negative sign of stress indicates compressive stress in a member or that the member is subjected to compression.

The equation (1.5) is not so convenient to use in engineering design so solving for this equation we get

$$N = \int \sigma dA \quad (1.6)$$

Brain power

By 2020, wind could provide one-tenth of our planet's electricity needs. Already today, SKF's innovative know-how is crucial to running a large proportion of the world's wind turbines.

Up to 25 % of the generating costs relate to maintenance. These can be reduced dramatically thanks to our systems for on-line condition monitoring and automatic lubrication. We help make it more economical to create cleaner, cheaper energy out of thin air.

By sharing our experience, expertise, and creativity, industries can boost performance beyond expectations. Therefore we need the best employees who can meet this challenge!

The Power of Knowledge Engineering

Plug into The Power of Knowledge Engineering.
Visit us at www.skf.com/knowledge

SKF

If we apply Saint Venant's principle, see Section 2.6 for more details, we can assume the uniform stress distribution function over the cross-section, except in the immediate vicinity of the loads points of application, thus we have

$$N = \sigma \int dA = \sigma A \quad \text{or} \quad \sigma = \frac{N}{A} \quad (1.7)$$

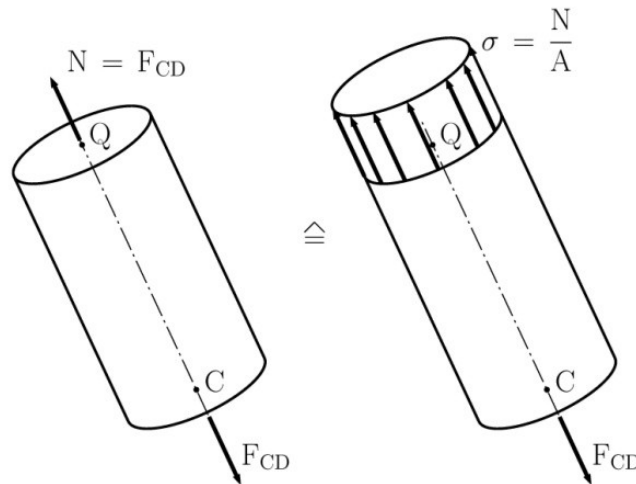


Fig. 1.10

A graphical representation is presented in Fig. 1.10. If an internal force N was obtained by the section passed perpendicular to the member axis, and the direction of the internal force N coincides with the member axis, then we are talking about *axially loaded members*. The direction of the internal force N also determines the direction of stress σ . Therefore we define this stress σ as *the normal stress*. Thus formula (1.7) determines the normal stress in the axially loaded member.

From elementary statics we get the resultant N of the internal forces, which then must be applied to the centre of the cross-section under the condition of uniformly distributed stress. This means that *a uniform distribution of stress is possible only if the action line of the applied loads passes through the centre of the section considered*, see Fig. 1.11. Sometimes we this type of loading is known as *centric loading*. In the case of an *eccentrically loaded member*, see Fig. 1.12, this condition is not satisfied, therefore the stress distribution function is not uniform. The explanation will be done in Chapter 4. The normal force $N_C = F$ and the moment $M_C = Fd$ are the internal forces obtained through the method of section.

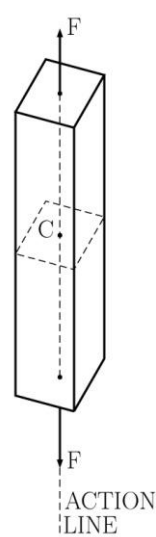


Fig. 1.11

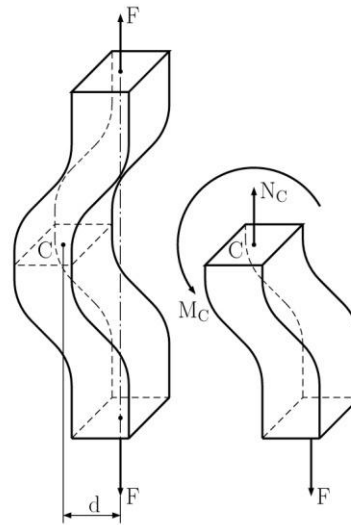
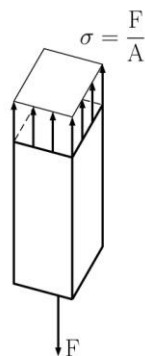


Fig. 1.12

1.4 Basic Stresses (Axial, Normal, Shearing and Bearing stress)

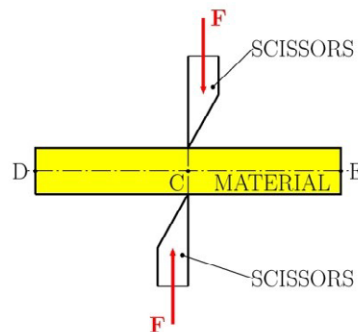


Fig. 1.13

In the previous Section we discussed the case when the resultant of internal forces and the resulting stress normal to the cross-section are considered. Now let us consider the cutting process of material using scissors, see Fig. 1.13. The applied load F is transversal to the axis of the member. Therefore the load F is called the transversal load. Thus we have a physically different stress. Let us pass a section through point C between the application points of two forces, see Fig. 1.14 (a). Detaching portion DC from the member we will get the diagram of the portion DC shown in Fig. 1.14(b). The zero valued internal forces are excluded. The resultant of internal forces is only the shear force. It is placed perpendicular to the member axis in the section and is equal to the applied force. The corresponding stress is called *the shearing stress* denoted by the Greek letter tau τ . Now we can define the shearing stress as In comparison to the normal stress, we cannot assume that the shearing stress is uniform over the cross-section. The proof of this statement is explained in Chapter 4. Therefore we can only calculate the average value of shearing stress:

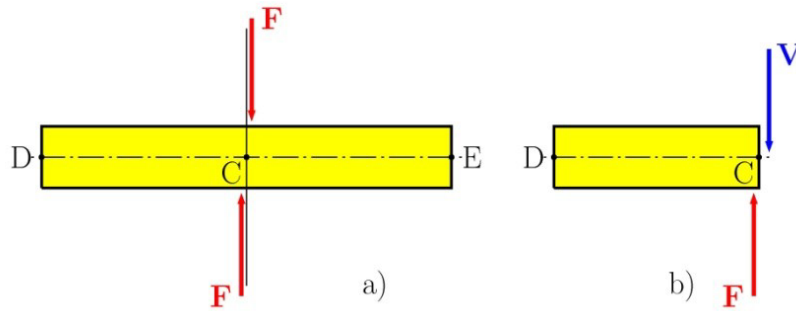


Fig. 1.14

$$\tau = \lim_{\Delta A \rightarrow 0} \frac{\Delta V}{\Delta A} = \frac{dV}{dA} \quad \text{or} \quad V = \int \tau dA \tag{1.8}$$

$$\tau_{ave} = \frac{V}{A} \tag{1.9}$$

The presented case of cutting is known as the *shear*.

The cutaway effect can be commonly found in bolts, screws, pins and rivets used to connect various structural components, see Fig. 1.15(a). Two plates are subjected to the tensile force F . The corresponding cutting stress will develop in plane CD . Considering the method of section in plane CD , for the top portion of the rivet, see Fig. 1.15(b), we obtain the shearing stress according to formula (1.9)

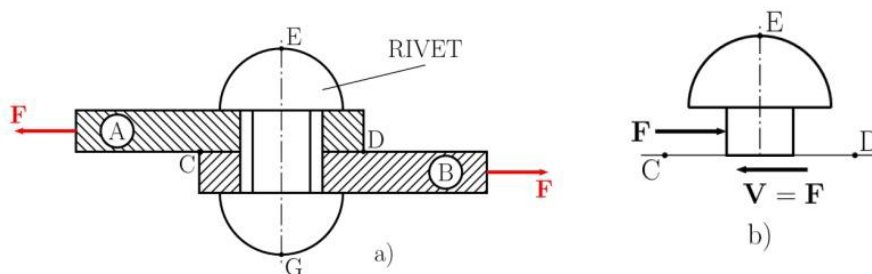


Fig. 1.15

$$\tau_{ave} = \frac{V}{A} = \frac{F}{A} \tag{1.10}$$

Until now we have discussed the application of section in a perpendicular direction to the member axis. Let us now consider the axially loaded member CD , see Fig. 1.16. If we pass the section at any arbitrary point Q over an angle θ between the perpendicular section and this arbitrary section, we will get the free body diagram shown in Fig. 1.17. From the free body diagram we see that the applied force F is in equilibrium with the axial force P , i.e. $P = F$. This axial force P represents the resultant of internal forces acting in this section. The components of axial force are

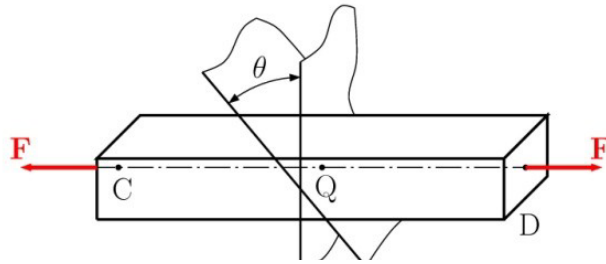


Fig. 1.16

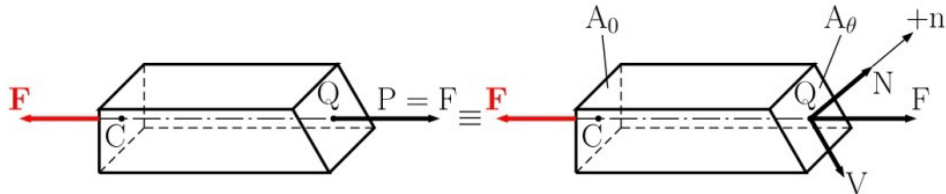


Fig. 1.17

$$N = P \cos \theta \quad \text{and} \quad V = P \sin \theta \quad (1.11)$$

> Apply now

REDEFINE YOUR FUTURE
AXA GLOBAL GRADUATE PROGRAM 2015

redefining / standards

agence.cdg © Photonistop



The normal force N and the shear force V represent the resultant of normal forces and shear forces respectively distributed over the cross-section and we can write the corresponding stresses over the cross-section $A_\theta = A_0/\cos\theta$ as follows

$$\sigma = \frac{N}{A_\theta} = \frac{P \cos \theta}{\frac{A_0}{\cos \theta}} = \frac{F}{A_0} \cos^2 \theta \quad (1.12)$$

$$\tau_{ave} = \frac{V}{A_\theta} = \frac{P \sin \theta}{\frac{A_0}{\cos \theta}} = \frac{F}{A_0} \sin \theta \cos \theta \quad (1.13)$$

For the perpendicular section, when $\theta = 0$, we get $\sigma = \sigma_{max} = \frac{F}{A_0}$ and $\tau_{ave} = 0$. These results correspond to the ones we found earlier. In the point of view of mathematics, the magnitudes of stresses depend upon the orientation of the section.

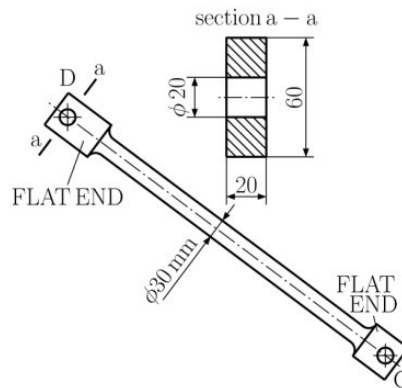


Fig. 1.18

The resultant stress from the normal and shearing stress components is called *the axial stress (the stress in the direction of the axis)* and it is denoted as p ; see Fig. 1.18. Then using elementary mathematics we get

$$p = \sqrt{\sigma^2 + \tau_{ave}^2} \quad (1.14)$$

The exact mathematical definition of the axial stress is the same as previously defined stress types, i.e.

$$p = \lim_{\Delta A \rightarrow 0} \frac{\Delta P}{\Delta A} = \frac{dP}{dA} \quad (1.15)$$

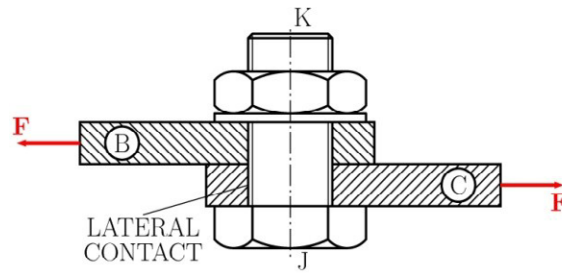


Fig. 1.19

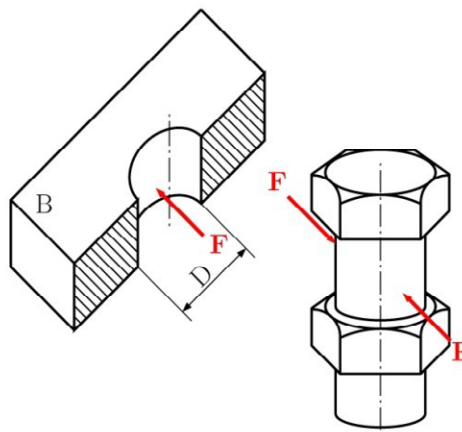


Fig. 1.20

LIGS University

based in Hawaii, USA

is currently enrolling in the
Interactive Online **BBA, MBA, MSc,**
DBA and PhD programs:

- ▶ enroll **by October 31st, 2014** and
- ▶ **save up to 11%** on the tuition!
- ▶ pay in 10 installments / 2 years
- ▶ Interactive **Online** education
- ▶ visit www.ligsuniversity.com to find out more!

Note: LIGS University is not accredited by any nationally recognized accrediting agency listed by the US Secretary of Education. More info [here](#).

Click on the ad to read more

Fittings, bolts, or screws have a lateral contact within the connected member, see Fig. 1.19. They create the stress in the connected member along the *bearing surface* or the *contact surface*. For example let us consider the bolt JK connecting two plates B and C , which are subjected to shear, see Fig. 1.19. The bolt shank exerts a force P on the plate B which is equal to the applied force F . The force P represents the resultant of all elementary forces distributed over the half of the cylindrical hole in plate B , see Fig. 1.20. The diameter of the cylindrical hole is D and the height is t . The distribution function of the aforementioned stresses is very complicated and therefore we usually use the average value of *contact* or *bearing stress*. In this case the average engineering bearing stress is defined as

$$\sigma_b = \frac{P}{A} = \frac{F}{A} = \frac{F}{Dt} \quad (1.16)$$

1.5 Application to the Analysis and Design of Simple Structures

Let us recall the simple truss structure that we discussed in Section 1.2, see Fig. 1.1. Let us now detach rod CD for a more detailed analysis, see Fig. 1.21. The detailed pin connection at point D is presented in Fig 1.22. The following stresses acting in the rod CD can be calculated

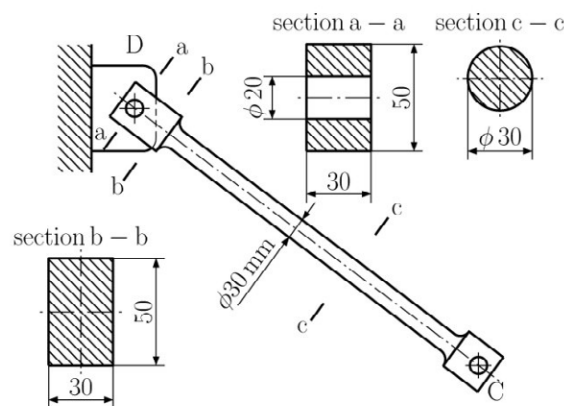


Fig. 1.21

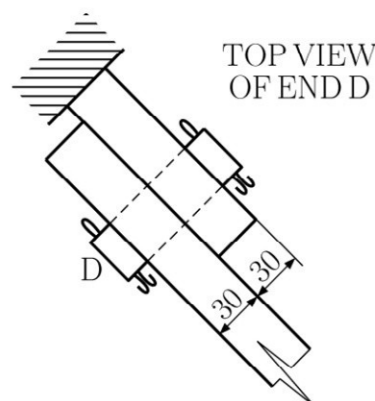


Fig. 1.22

- The normal stress in the shank of the rod CD :

The normal force acting in the circular shank is $F_{CD} = 25 \text{ kN}$, the corresponding cross-sectional area is $A_{shank} = \pi \left(\frac{30}{2}\right)^2 = 706,9 \text{ mm}^2$. Then we have

$$\sigma_{shank} = \frac{F_{CD}}{A_{shank}} = \frac{25000 \text{ N}}{706,9 \text{ mm}^2} = 35,4 \text{ MPa}$$

- The normal stresses in the flat end of D :

The normal force acting in the flat end is $F_{CD} = 25 \text{ kN}$ again, the corresponding cross-sectional areas are at the section $a-a$ $A_{aa} = (50 - 20) \cdot 30 = 900 \text{ mm}^2$ and at the section $b-b$ $A_{bb} = 50 \cdot 30 = 1500 \text{ mm}^2$. Thus we get

$$\sigma_{aa} = \frac{F_{CD}}{A_{aa}} = \frac{25000 \text{ N}}{900 \text{ mm}^2} = 27,8 \text{ MPa} \quad \text{and} \quad \sigma_{bb} = \frac{F_{CD}}{A_{bb}} = \frac{25000 \text{ N}}{1500 \text{ mm}^2} = 16,7 \text{ MPa}$$

- The shearing stress in the pin connection D :

The shear force acting in the pin is $F_{CD} = 25 \text{ kN}$, the corresponding cross-sectional area is $A_{pin} = \pi \left(\frac{20}{2}\right)^2 = 314,2 \text{ mm}^2$. Then we have

$$\tau_{pin} = \frac{F_{CD}}{A_{pin}} = \frac{25000 \text{ N}}{314,2 \text{ mm}^2} = 79,6 \text{ MPa}$$

- The bearing stress at D :

The contact force acting in the cylindrical hole is $F_{bearing} = 25 \text{ kN}$, the corresponding cross-sectional area is $A_{bearing} = 30 \cdot 30 = 900 \text{ mm}^2$. Using formula (1.16) we get

$$\sigma_{bearing} = \frac{F_{bearing}}{A_{bearing}} = \frac{25000 \text{ N}}{900 \text{ mm}^2} = 27,8 \text{ MPa}$$

1.6 Method of Problem Solution and Numerical Accuracy

Every formula previously mentioned and derived has its own validity. This validity predicts the application area, i.e. the limitations on the applicability. Our solution must be based on the fundamental principles of statics and mechanics of materials. Every step, which we apply in our approach, must be justified on this basis. After obtaining the results, they must be checked. If there is any doubt in the results obtained, we should check the problem formulation, the validity of applied methods, input data (material parameters, boundary conditions) and the accuracy of computations.

The method of problem solution is the *step-by-step solution*. This approach consists of the following steps:

- i. Clear and precise problem formulation. This formulation should contain the given data and indicate what information is required.
- ii. Simplified drawing of a given problem, which indicates all essential quantities, which should be included.
- iii. Free body diagram to obtaining reactions at the supports.
- iv. Applying method of section in order to obtain the internal forces and moments.
- v. Solution of problem oriented equations in order to determine stresses, strains, and deformations.

Subsequently we have to check the results obtained with respect to some simplifications, for example boundary conditions, the neglect of some structural details, etc.

The numerical accuracy depends upon the following items:

- the accuracy of input data;
- the accuracy of the computation performed.

TURN TO THE EXPERTS FOR **SUBSCRIPTION** CONSULTANCY

Subscribe is one of the leading companies in Europe when it comes to innovation and business development within subscription businesses.

We innovate new subscription business models or improve existing ones. We do business reviews of existing subscription businesses and we develop acquisition and retention strategies.

Learn more at [linkedin.com/company/subscribe](https://www.linkedin.com/company/subscribe) or contact
Managing Director Morten Suhr Hansen at mha@subscribe.dk

SUBSCR✓**BE** - to the future

For example it is possible that we can get inaccurate material parameters. Let us consider an error of 5% in Young's modulus. Then the calculation of stress contains at least the same error, the explanation can be found in Section 2.5. The accuracy of computation is tightly connected with the computational method applied. We can apply either the analytical solution or the iterative solution.

1.7 Components of Stress under General Loading Conditions

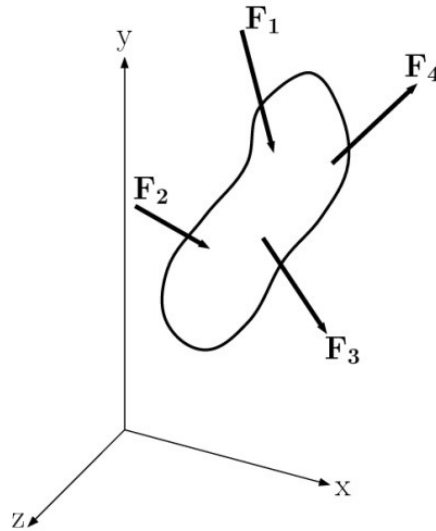


Fig. 1.23

Until now we have limited the discussion to axially loaded members. Let us generalise the results obtained in the previous sections. Thus we can consider a body subjected to several forces, see Fig. 1.23. To analyse the stress conditions created by the loads inside the body, we must apply the method of sections. Let us analyse stresses at an arbitrary point Q. The Euclidian space is defined by three perpendicular planes, therefore we will pass three parallel sections to the Euclidian ones through point Q.

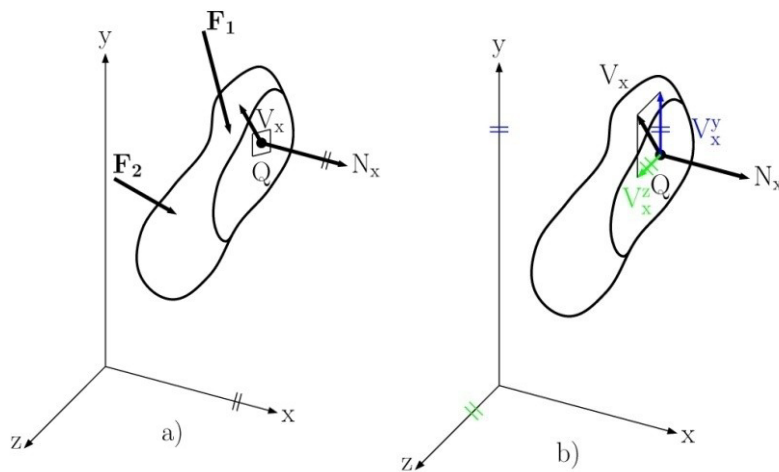


Fig 1.24

Firstly we pass a section parallel to the principal plane yz , see Fig. 1.24 and take into account the left portion of the body. This portion is subjected to the applied forces and the resultants of all internal forces (these forces replace the effect of the removed part). In our case we have the normal force N_x and the shear force V_x . The lower subscript means the direction of the positive outgoing normal. The general shear force V_x has two components in the directions of y and z , i.e. V_x^y and V_x^z . The superscript indicates the direction of the shear component. For determining the stress distributions over the section we need to define a small area ΔA surrounding point Q , see Fig. 1.24. Then the corresponding internal forces are ΔN_x , ΔV_x^y , ΔV_x^z . Recalling the mathematical definition of stress in equations (1.5) and (1.8), we get

$$\sigma_x = \lim_{\Delta A \rightarrow 0} \frac{\Delta N_x}{\Delta A} \quad \tau_{xy} = \lim_{\Delta A \rightarrow 0} \frac{\Delta V_x^y}{\Delta A} \quad \tau_{xz} = \lim_{\Delta A \rightarrow 0} \frac{\Delta V_x^z}{\Delta A} \quad (1.17)$$

These results are presented in Fig.1.25 Remember that the first subscript in σ_x , τ_{xy} and τ_{xz} is used to indicate that the stresses under consideration are exerted *on a surface perpendicular to the x axis*. The second subscript in the shearing stresses identifies the direction of the component. The same results will be obtained if we apply the same approach for the right side of the body considered, see Fig. 1.26.

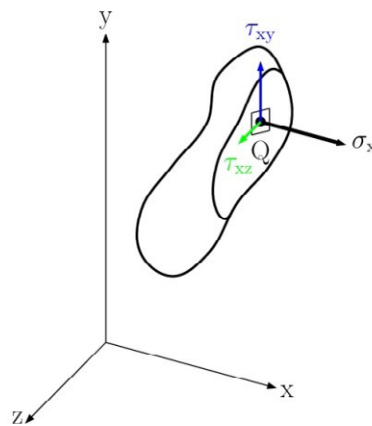


Fig. 1.25

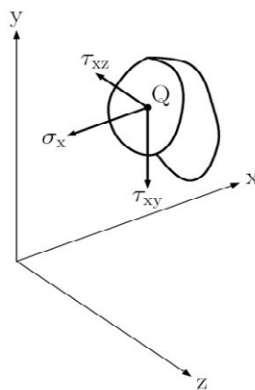


Fig.1.26

Secondly we now pass a section parallel to the principal plane of xz , where we will get the stress components: σ_y , τ_{yx} and τ_{yz} in a similar way. Thirdly, passing a section parallel to the principal plane of xy , we can also get the stress components: σ_z , τ_{zx} and τ_{zy} by the same way. Thus the stress state at point Q is defined by nine stress components. With respect to statics, it is a statically indeterminate problem, since we only have six equilibrium equations.

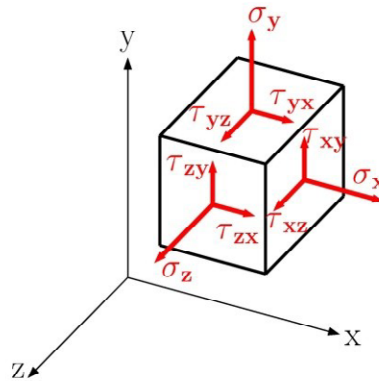


Fig. 1.27

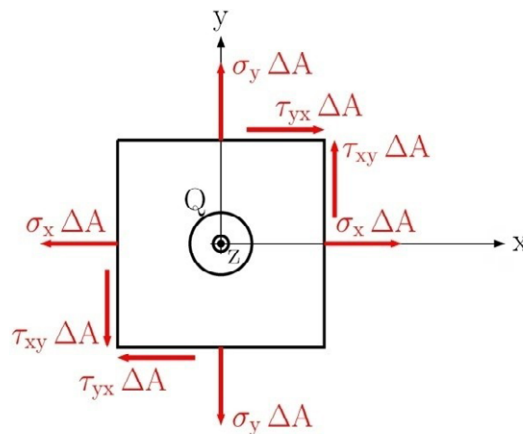


Fig. 1.28

To visualise the stress conditions at point Q , we can represent point Q as a small cube, see Fig. 1.27. There are only three faces of the cube visible in Fig. 1.27. The stresses on the hidden parallel faces are equal and opposite of the visible ones. Such a cube must satisfy the condition of equilibrium. Therefore we can multiply the stresses by the face area ΔA to obtain the forces acting on the cube faces. Focusing on the moment equation about the local z axis, see Fig. 1.28 and assuming the positive moment in the counter-clockwise direction, we have

$$\sum M_z = 0 \quad \tau_{xy} \Delta A \frac{a}{2} - \tau_{yx} \Delta A \frac{a}{2} + \tau_{xy} \Delta A \frac{a}{2} - \tau_{yx} \Delta A \frac{a}{2} = 0 \tag{1.18}$$

we then conclude

$$\tau_{xy} = \tau_{yx} \tag{1.19}$$

The relation obtained shows that the y component of the shearing stress exerted on a face perpendicular to the x axis is equal to the x component of the shearing exerted on a face perpendicular to the y axis. Similar results will be obtained for the rest of the moment equilibrium equations, i.e.

$$\tau_{xz} = \tau_{zx} \quad \text{and} \quad \tau_{yz} = \tau_{zy} \quad (1.20)$$

The equations (1.19) and (1.20) represent the *shear law*. The explanation of the shear law is: if the shearing stress exerts on any plane, then the shearing stress will also exert on the perpendicular plane to that one. Thus the stress state at any arbitrary point is determined by six stress components: $\sigma_x, \sigma_y, \sigma_z, \tau_{xy}, \tau_{xz}, \tau_{yz}$.

1.8 Design Considerations and Factor of Safety

In the previous sections we discussed the stress analysis of existing structures. In engineering applications we must design with safety as well as economical acceptability in mind. To reach this compromise stress analyses assists us in fulfilling this task. The design procedure consists of the following steps:

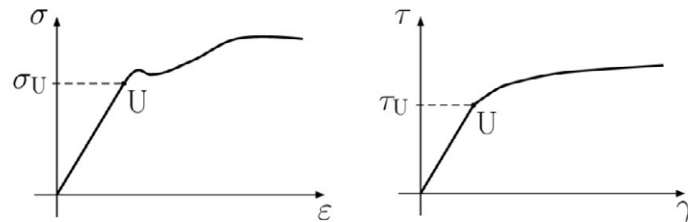


Fig. 1.29

“I studied English for 16 years but...
...I finally learned to speak it in just six lessons”
Jane, Chinese architect

ENGLISH OUT THERE

Click to hear me talking before and after my unique course download

- *Determination of the ultimate stress of a material.* A certified laboratory will make material tests in respect to the defined load. For example they can determine the *ultimate tensile stress*, the *ultimate compressive stress* and the *ultimate shearing stress* for a given material, see Fig. 1.29.
- *Allowable load and allowable stress, Factor of Safety.* Due to any unforeseen loading during the structures operation, the maximum stress in the designed structure can not be equal to the ultimate stress. Usually the maximum stress is less than this ultimate stress. Low stress corresponds to the smaller loads. This smaller loading we call the *allowable load* or *design load*. The ratio of the ultimate load to the allowable load is used to define the *Factor of Safety* which is:

$$\text{Factor of Safety} = F.S. = \frac{\text{Ultimate load}}{\text{Allowable load}} \quad (1.21)$$

An alternative of this definition can be applied to stresses:

$$\text{Factor of Safety} = F.S. = \frac{\text{Ultimate stress}}{\text{Allowable stress}} \quad (1.22)$$

- *Selecting the appropriate Factor of Safety.* The appropriate Factor of Safety (F.S.) for a given design application requires good engineering judgment based on many considerations, such as the following:
 - Type of loading, i.e. static or dynamic or random loading.
 - Variation of material properties, i.e. composite structure of different materials.
 - Type of failure that is expected, i.e. brittle or ductile failure, etc.
 - Importance of a given member, i.e. less important members can be designed with allowed F.S.
 - Uncertainty due to the analysis method. Usually we use some simplifications in our analysis.
 - The nature of operation, i.e. taking into account the properties of our surrounding, for example: corrosion properties.

For the majority of structures, the recommended F.S. is specified by structural Standards and other documents written by engineering authorities.

2 Stress and Strain – Axial Loading

2.1 Introduction

In the previous chapter we discussed the stresses produced in the structures under various conditions, i.e. loading, boundary conditions. We have analyzed the stresses in simply loaded members and we learned how to design some characteristic dimensions of these members due to allowable stress. Another important aspect in the design and analysis of structures are their deformations, and the reasons are very simple. For example, large deformations in the structure as a result of the stress conditions under the applied load should be avoided. The design of a bridge can fulfil the condition for allowable stress but the deformation (in our case deflection) at mid-span may not be acceptable. The deformation analysis is very helpful in the stress determination too, mainly for statically indetermined problems. Statically it is assumed that the structure is a composition of rigid bodies. But now we would like to analyse the structure as a deformable body.

2.2 Normal Stress and Strain under Axial Loading

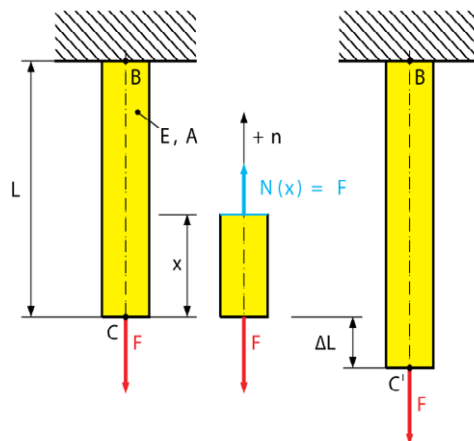


Fig. 2.1

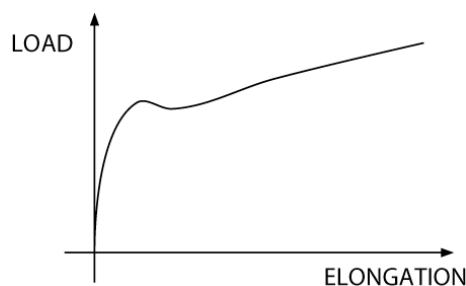


Fig. 2.2

Let us assume that the rod BC , of length L with constant cross-sectional area A , is hanging on a fixed point B , see Fig. 2.1 . If we apply the load F we can observe an elongation of the rod BC . Both the applied force and elongation can be measured. And we can plot the load vs. elongation, see Fig. 2.2.

As we mentioned in the previous chapter, we would like to avoid plotting geometrical characteristics, i.e. cross-sectional area and length. We cannot use such a graph directly to predict the rod elongation of the same material with different dimensions. Let us consider the following examples:

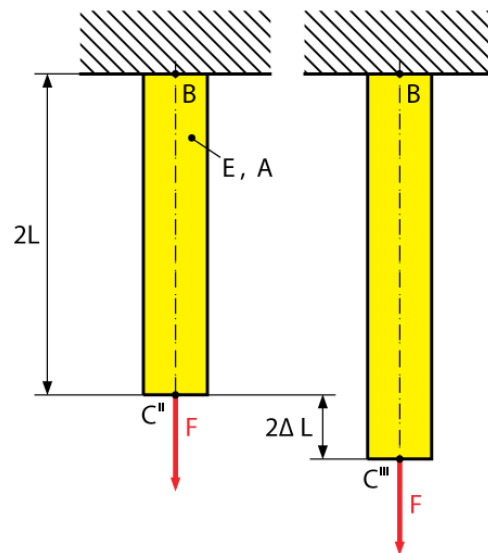


Fig. 2.3

How to retain your top staff

FIND OUT NOW FOR FREE

DO YOU WANT TO KNOW:

- What your staff really want?
- The top issues troubling them?
- How to make staff assessments work for you & them, painlessly?

[Get your free trial](#)

Because happy staff get more done

The applied load F causes the elongation ΔL . The corresponding normal stress can be found by passing a section perpendicular to the axis of the rod (method of sections) applying this method we obtain $\sigma_x = \frac{N(x)}{A} = F/A$, see Fig. 2.1. If we apply the same load to the rod of length $2L$ and the same cross-sectional area A , we will observe an elongation of $2\Delta L$ with the same normal stress $\sigma_x = F/A$, see Fig. 2.3. This means the deformation is twice as large as the previous case. But the ratio of deformation over the rod length is the same, i.e. is equal to $\Delta L/L$. This result brings us to the concept of strain.

We can now define the normal strain ε caused by axial loading as the deformation per unit length of the rod. Since length and elongation have the same units, the normal strain is a dimensionless quantity. Mathematically, we can express the normal strain by:

$$\varepsilon_x = \frac{\Delta L}{L} \quad (2.1)$$

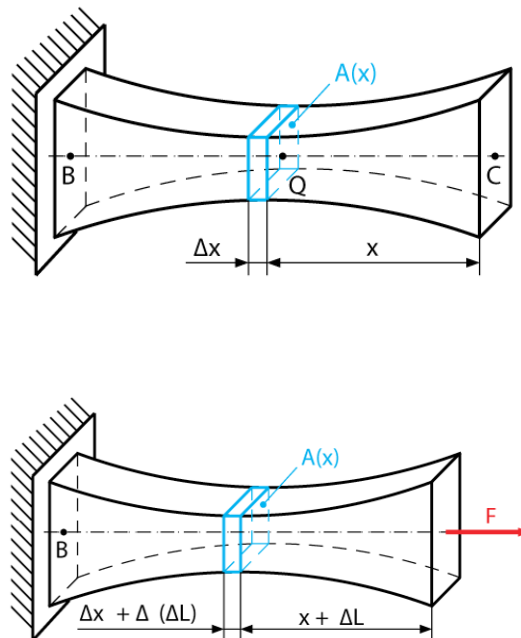


Fig. 2.4

This equation is valid only for a rod with constant cross-sectional area. In the case of variable cross sectional area, the normal stress varies over the axis of the rod by $\sigma_x = F/A(x)$. Then we must define the normal strain at an arbitrary point Q by considering a small element of undeformed length Dx . The corresponding elongation of this element is $D(\Delta L)$, see Fig. 2.4. Thus we can define the normal strain at point Q as:

$$\varepsilon_x = \lim_{\Delta x \rightarrow 0} \frac{\Delta(\Delta L)}{\Delta x} = \frac{d\Delta L}{dx} \quad (2.2)$$

which again, results in a dimensionless quantity.

2.3 Stress-Strain Diagram, Hooke’s Law, and Modulus of Elasticity

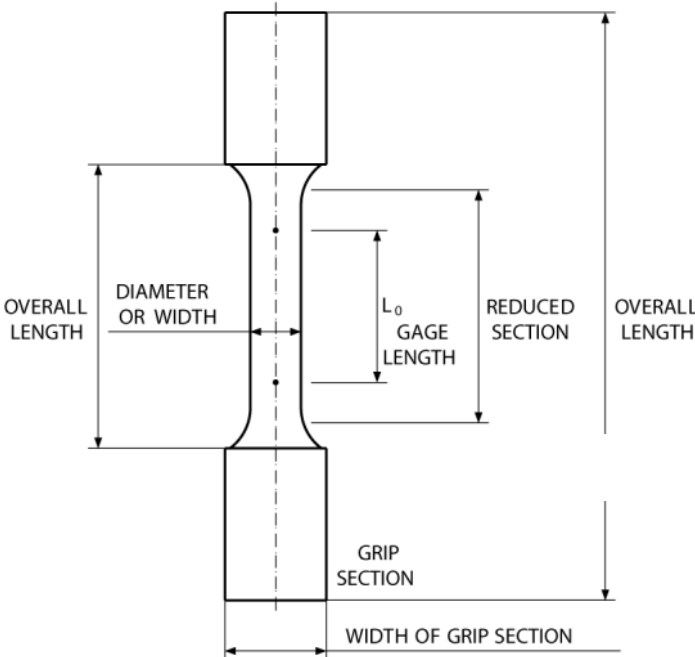


Fig. 2.5 Test specimen



Fig. 2.6 MTS testing machine, see www.mts.com

As we discussed before, plotting load vs. elongation is not useful for engineers and designers due to their strong sensitivity on the sample geometry. Therefore we explained the concepts of stress and strain in Sec. 1.3 and Sec. 2.2 in detail. The result is a stress-strain diagram that represents the relationship between stress and strain. This diagram is an important characteristic of material and can be obtained by conducting a tensile test. The typical specimen can be shown in Fig. 2.5. The cross-sectional area of the cylindrical central portion of the specimen has been accurately determined and two gage marks have been made in this portion at a distance L_0 from each other. The distance L_0 is known as the *gage length* (or *referential length*) of the specimen. The specimen is then placed into the test machine seen in Fig. 2.6, which is used for centric load application. As the load F increases, the distance L between gage marks also increases. The distance can be measured by several mechanical gages and both quantities (load and distance) are recorded continuously as the load increases. As a result we obtain the total elongation of the cylindrical portion $DL=L-L_0$ for each corresponding load step. From the measured quantities we can recalculate the values of stress and strain using equations (1.5) and (2.1). For different materials we obtain different stress-strain diagrams. In Fig. 2.7 one can see the typical diagrams for ductile and brittle materials.

gaiTeye
Challenge the way we run

EXPERIENCE THE POWER OF FULL ENGAGEMENT...

**RUN FASTER.
RUN LONGER..
RUN EASIER...**

**READ MORE & PRE-ORDER TODAY
WWW.GAITEYE.COM**

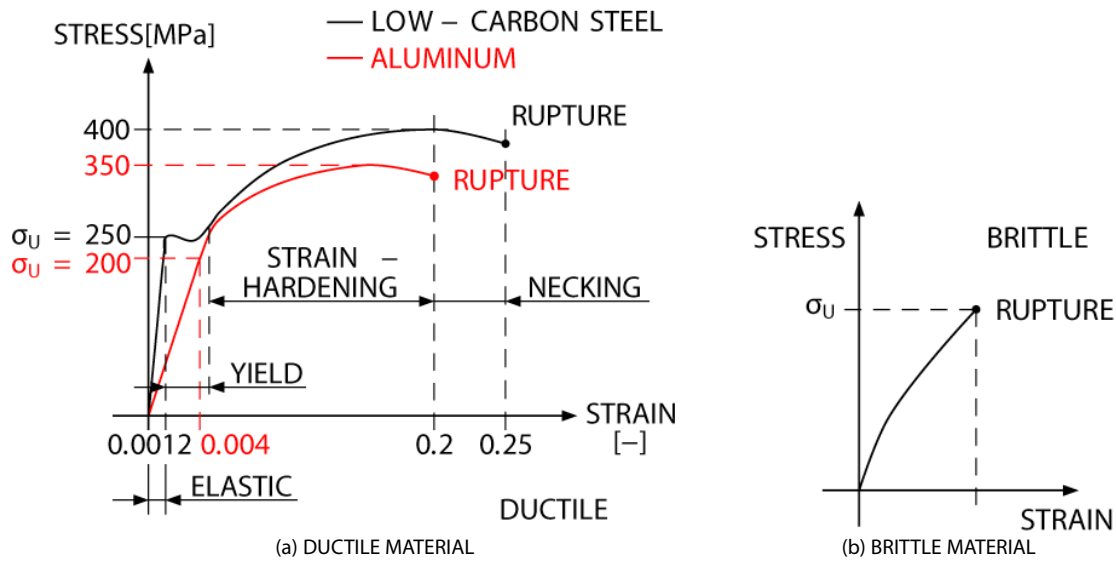


Fig. 2.7

For a more detailed discussion about the diagrams we recommend any book which is concerned with material sciences for engineers.

Many engineering applications undergo small deformations and small strains. Thus the response of material can be expected in an elastic region. For many engineering materials the elastic response is linear, i.e. the straight line portion in a stress-strain diagram. Therefore we can write:

$$\sigma_x = E \varepsilon_x \quad (2.3)$$

This equation is the well-known *Hooke's law*, found by Robert Hooke (1635–1703), the English pioneer of applied mechanics. The coefficient E is called *the modulus of elasticity* for a given material, or *Young's modulus*, named after the English scientist Thomas Young (1773–1829). Since the strain ε is a dimensionless quantity, then the modulus of elasticity E has the same units as the stress σ , in Pascals. The physical meaning of the modulus of elasticity is the stress occurring in a material undergoing a strain equal to one, i.e. the measured specimen is elongated from its initial length L_0 .

If the response of the material is independent from the direction of loading, it is known as *isotropic*. Materials whose properties depend upon the direction of loading are *anisotropic*. Typical example of anisotropic materials are laminates, composites etc.

2.4 Poisson's Ratio

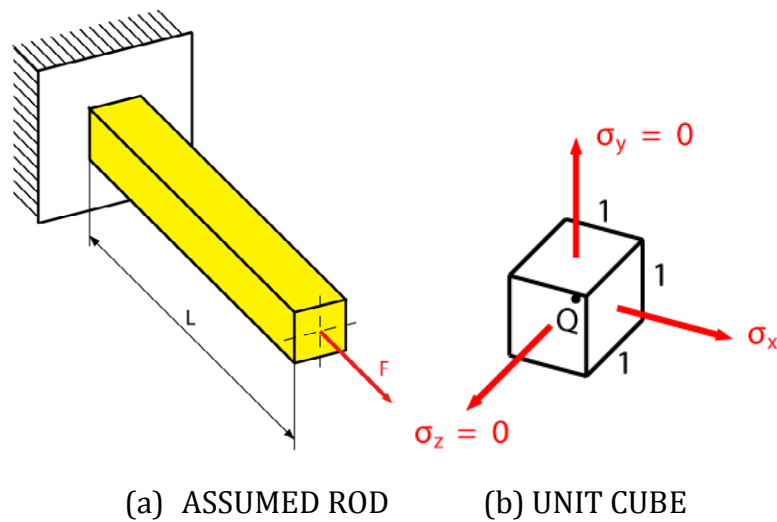


Fig. 2.8

As we can see in the previous sections (2.2 and 2.3) the normal stress and strain have the same direction as the applied load. Let us assume that the homogenous and isotropic rod is axially loaded by a force F as in Fig. 2.8. Then the corresponding normal stress is $\sigma_x = \frac{N(x)}{A} = F/A$ and applying Hooke's law we obtain:

$$\varepsilon_x = \frac{\sigma_x}{E} = \frac{F}{EA} \quad (2.3)$$

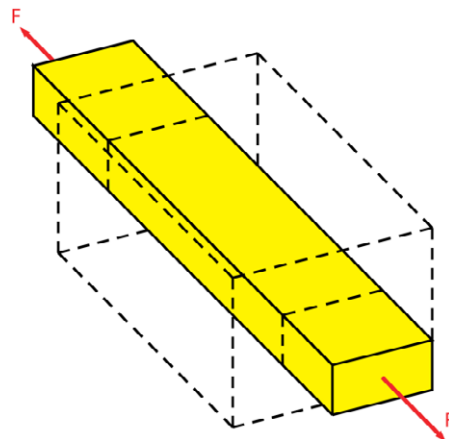


Fig. 2.9

It is natural to assume that normal stresses on the faces of a unit cube which represents the arbitrary point Q are zero. $\sigma_y = \sigma_z = 0$. This could convince one to assume that the corresponding strains $\varepsilon_y, \varepsilon_z$ are zero too. But this is not our case. In many engineering materials the elongation in the direction of applied load is accompanied with a contraction in any transversal direction, see Fig. 2.9. We are assuming homogeneous and isotropic materials, i.e. mechanical properties are independent of position and direction. Therefore we have $\varepsilon_y = \varepsilon_z$. This common value is called the *lateral strain*. Now we can define the important material constant: *Poisson's ratio*, named after Simeon Dennis Poisson (1781–1840), as:

$$\nu = -\frac{\text{lateral strain}}{\text{axial strain}} \quad (2.4)$$

or

$$\nu = -\frac{\varepsilon_y}{\varepsilon_x} = -\frac{\varepsilon_z}{\varepsilon_x} \quad (2.5)$$

Note that the contraction in the lateral direction means that the reduction of lateral dimension return a negative value of strain and a positive value of Poisson's ratio. Usually Poisson's ratio has a value within the interval of $(0, \frac{1}{2})$ for common engineering materials like steel, iron, brass, aluminium, etc. If we apply Hooke's law and eq. (2.5) we will obtain the following strains:

$$\varepsilon_x = \frac{\sigma_x}{E} = \frac{F}{EA} \quad \text{and} \quad \varepsilon_y = \varepsilon_z = -\frac{\nu\sigma_x}{E} = -\frac{\nu F}{EA} \quad (2.6)$$

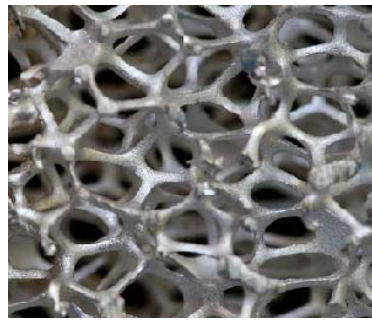
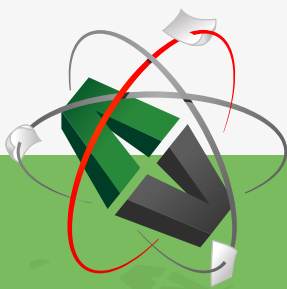


Fig. 2.10 Open foam

This e-book
is made with
SetaPDF



PDF components for PHP developers

www.setasign.com



Naturally, there exist some materials with a negative value of Poisson's ratio. These materials are known as cellular, i.e. foams and honeycombs. Instead of contraction, they elongate in the lateral direction. The structure of these materials is presented in Fig. 2.10. For more information see any book written by L.J. Gibson and M.F. Ashby.

2.5 Generalised Hooke's Law for Multiaxial Loading

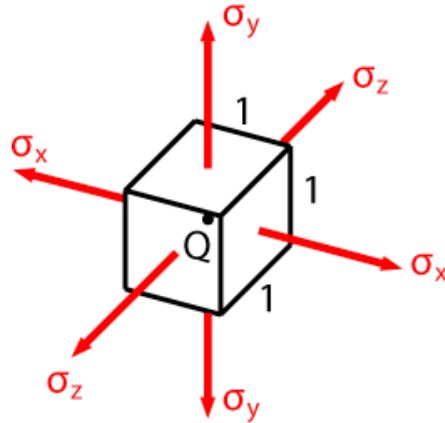


Fig. 2.11

Until now we have discussed slender members (rods, bars) under axial loading alone. This resulted in a stress state at any arbitrary point of Q : $\sigma_x = \frac{F}{A}$, $\sigma_y = \sigma_z = 0$. Now let us consider multiaxial loading acting in the direction of all three coordinate axes and producing non-zero normal stresses: $\sigma_x \neq \sigma_y \neq \sigma_z \neq 0$, see Fig. 2.11.

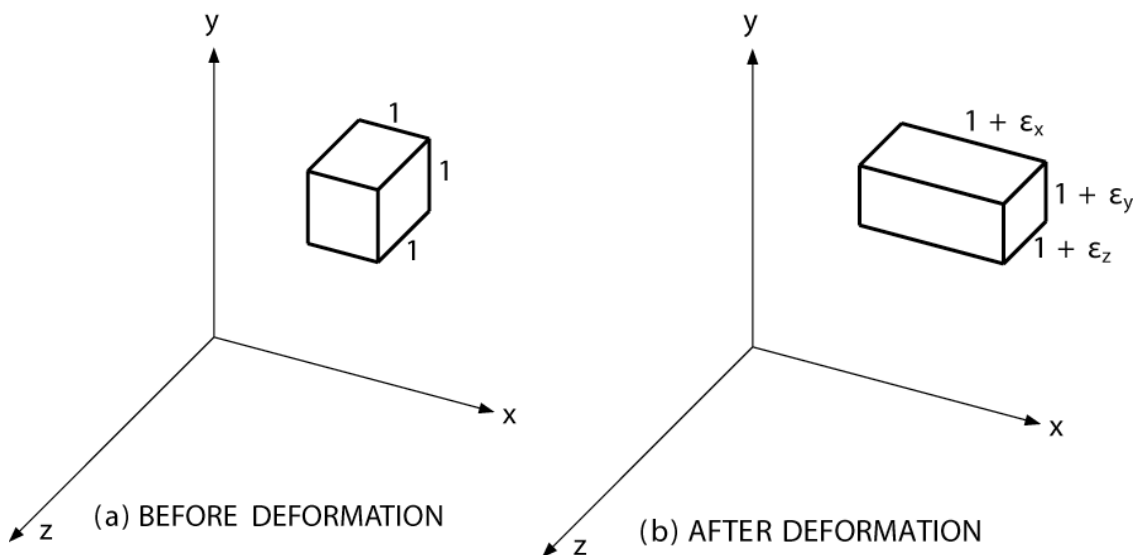


Fig. 2.12

Let us consider that our material is isotropic and homogeneous. Our arbitrary point Q is represented by a unit cube (where the dimensions of each side are a unit of the length), see Fig. 2.12. Under the given multiaxial loading the unit cube is deformed into a rectangular parallelepiped with the following sides: $(1 + \varepsilon_x)$, $(1 + \varepsilon_y)$, $(1 + \varepsilon_z)$, where ε_x , ε_y , ε_z are strains in the directions of the coordinate axes seen in Fig. 2.12(b). It is necessary to emphasize that the unit cube is undergoing the deformation motion only with no rigid motion (translation). Then we can express the strain components ε_x , ε_y , ε_z in terms of the stress components σ_x , σ_y , σ_z . For this purpose, we will first consider the effect of each stress component separately. Secondly we will combine the effects of all contributing stress components by applying the principle of superposition. This principle states that the final effect of combined loading can be obtained by determining the effects for individual loads separately and subsequently these separate effects are combined into the final result.

In our case the strain components are caused by the stress component σ_x : in the x direction $\varepsilon'_x = \sigma_x/E$ and in the y and z directions $\varepsilon'_y = \varepsilon'_z = -\nu\sigma_x/E$ recalling eq. (2.6). Similarly, the stress component σ_y causes the strain components: in the y direction $\varepsilon''_y = \sigma_y/E$ and in x and z directions $\varepsilon''_x = \varepsilon''_z = -\nu\sigma_y/E$. And finally the stress component σ_z causes the strain components: in z direction $\varepsilon'''_z = \sigma_z/E$ and in x and y directions $\varepsilon'''_x = \varepsilon'''_y = -\nu\sigma_z/E$. These are separate effects of individual stress components. The final strain components are then the sums of individual contributions, i.e.

$$\begin{aligned}\varepsilon_x &= \varepsilon'_x + \varepsilon''_x + \varepsilon'''_x = \frac{\sigma_x}{E} - \frac{\nu\sigma_y}{E} - \frac{\nu\sigma_z}{E} \\ \varepsilon_y &= \varepsilon'_y + \varepsilon''_y + \varepsilon'''_y = -\frac{\nu\sigma_x}{E} + \frac{\sigma_y}{E} - \frac{\nu\sigma_z}{E} \\ \varepsilon_z &= \varepsilon'_z + \varepsilon''_z + \varepsilon'''_z = -\frac{\nu\sigma_x}{E} - \frac{\nu\sigma_y}{E} + \frac{\sigma_z}{E}\end{aligned}\quad (2.7)$$

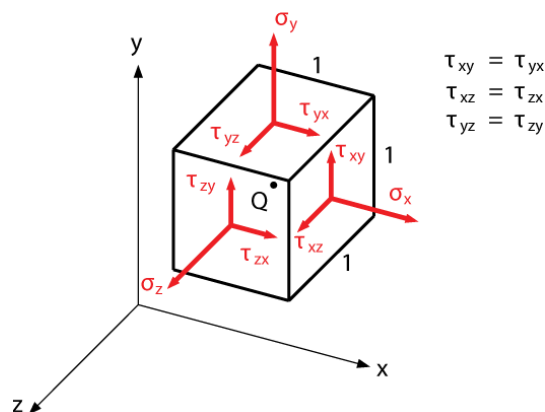


Fig. 2.13

The equation (2.7) are known as a part of the generalised Hooke's law or a part of the elasticity equations for homogeneous and isotropic materials.

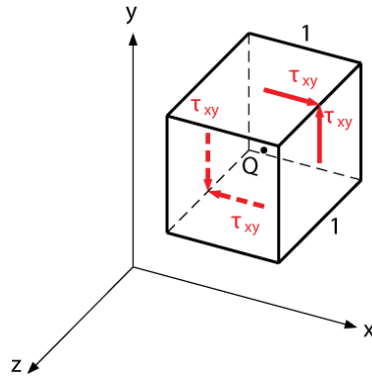


Fig. 2.14

Until now, shearing stresses have not been involved in our discussion. Therefore consider the more generalized stress state defines with six stress components $\sigma_x, \sigma_y, \sigma_z, \tau_{xy}, \tau_{xz}, \tau_{yz}$, see Fig. 2.13. The shearing stresses $\tau_{xy}, \tau_{xz}, \tau_{yz}$ have no direct effect on normal strains, as long as the deformations remain small. In this case there is no effect on validity of equation (2.7). The occurrence of shearing stresses is clearly observable. Since the shearing stresses tend to deform the unit cube into a oblique parallelepiped.



Discover the truth at www.deloitte.ca/careers

Deloitte.

© Deloitte & Touche LLP and affiliated entities.



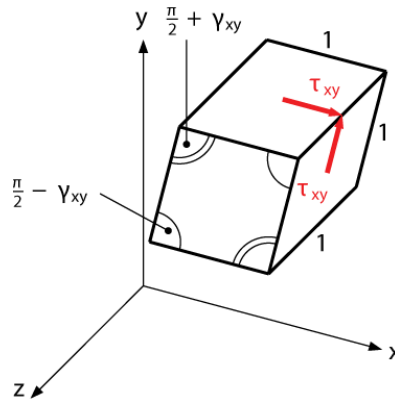


Fig. 2.15

For simplicity, let us consider a unit cube of material which undergoes a simple shear in the xy plane, see Fig. 2.14. The unit cube is deformed into the rhomboid with sides equal to one, see Fig. 2.15. In other words, shearing stresses cause the shape changes while normal stresses cause the volume changes. Let us focus on the angular changes. The four angles undergo a change in their values. Two of them reduced their values from $\frac{\pi}{2}$ to $\frac{\pi}{2} - \gamma_{xy}$ while the other two increase from $\frac{\pi}{2}$ to $\frac{\pi}{2} + \gamma_{xy}$. This angular change γ_{xy} (measured in radians) defines the *shearing strain* in both directions x and y . The shearing strain is positive if the reduced angle is formed by two faces with the same direction as the positive x and y axes, see Fig. 2.15. Otherwise it is negative.

In a similar way as the normal stress-strain diagram for tensile test we can obtain the shear stress-strain plot for simple shear or simple torsion, discussed in Chapter 3. From a mathematical point of view we can write Hooke's law for the straight part of the diagram by:

$$\tau_{xy} = G\gamma_{xy} \quad (2.8)$$

The material constant G is the *shear modulus* for any given material and has the similar physical meaning as Young's modulus.

If we consider shear in the xz and yz planes we will get similar solutions to Eq. (2.8) for stresses in those planes, i.e.

$$\tau_{xz} = G\gamma_{xz} \quad \tau_{yz} = G\gamma_{yz} \quad (2.9)$$

Finally we can conclude that the generalised Hooke's law or elasticity equations for the generalised stress state are written by:

$$\begin{aligned}\varepsilon_x &= \frac{\sigma_x}{E} - \frac{\nu\sigma_y}{E} - \frac{\nu\sigma_z}{E} \\ \varepsilon_y &= -\frac{\nu\sigma_x}{E} + \frac{\sigma_y}{E} - \frac{\nu\sigma_z}{E} \\ \varepsilon_z &= -\frac{\nu\sigma_x}{E} - \frac{\nu\sigma_y}{E} + \frac{\sigma_z}{E}\end{aligned}\quad (2.10)$$

$$\gamma_{xy} = \frac{\tau_{xy}}{G}$$

$$\gamma_{xz} = \frac{\tau_{xz}}{G}$$

$$\gamma_{yz} = \frac{\tau_{yz}}{G}$$

The validity of these equations is limited to isotropic materials, the proportionality limit stress that can not be exceeded by none of the stresses, and the superposition principle. Equation (2.10) contains three material constants E , G , ν that must be determined experimentally. In reality we need only two of them, because the following relationship can be derived

$$G = \frac{E}{2(1+\nu)} \quad (2.11)$$

2.6 Saint Venant's Principle



Fig. 2.16

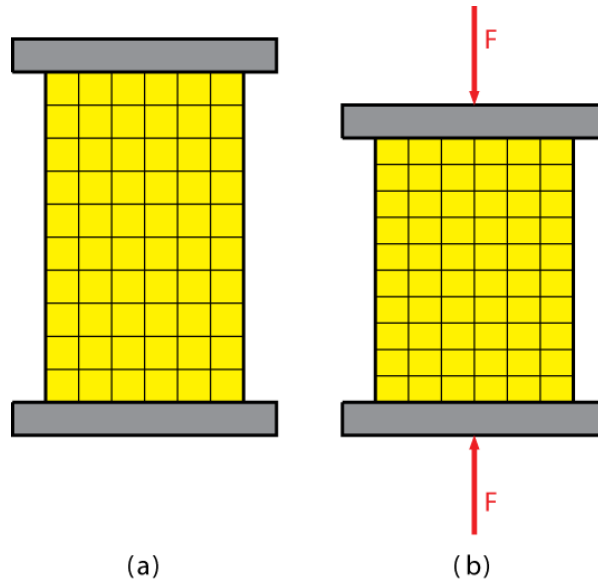


Fig. 2.17

Until now we have discussed axially loaded members (bars, rods) with uniformly distributed stress over the cross-section perpendicular to the axis of the member. This assumption can cause errors in the vicinity of load application. For simplicity let us consider a homogeneous rubber-like member that is axially loaded by a compressive force F , see Fig. 2.16. Let us make the following two experiments. Firstly, we draw a squared mesh over the member; see Fig. 2.17(a). Then we apply the compressive load through two rigid plates; see Fig. 2.17(b). The member is deformed in such a manner that it remains straight but the original square element change into a rectangular elements, see Fig. 2.17(b). The deformed mesh is uniform; therefore the strain distribution over a perpendicular cross-section is also uniform. If the strain is uniform, then we can conclude that the stress distribution is also similarly uniform described by Hooke's law. Secondly we apply the compressive force to the same meshed member throughout the sharp points, see Fig. 2.18. This is the effect of a concentrated load. We can observe strong deformations in the vicinity of the load application point. At certain distances from the end of a member the mesh is again uniform and rectangular. Therefore we can say that there are large deformations and stresses around the load application point while uniform deformations and stresses occur farther from this point. In other words, except for the vicinity of load application point, the stress distribution function may be assumed independently to the load application mode. This statement which can be applicable to any type of loading is known as *Saint-Venant's principle*, after Adhémar Barré de Saint-Venant (1797–1886).

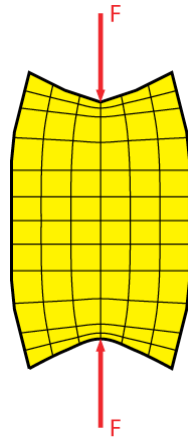


Fig. 2.18

While Saint-Venant’s principle makes it possible to replace actual loading with a simpler one for computational purposes, we need to keep in mind the following:

- The actual loading and loading used to compute stresses must be statically equivalent.
- Stresses cannot be computed in the vicinity of load application point. In these cases advanced theoretical and experimental method must be applied for stress determination.

© 2013 Accenture. All rights reserved.

be > your degree

Bring your talent and passion to a global organization at the forefront of business, technology and innovation. Discover how great you can be.

Visit accenture.com/bookboon

Be greater than.
consulting | technology | outsourcing

accenture
High performance. Delivered.



2.7 Deformations of Axially Loaded Members

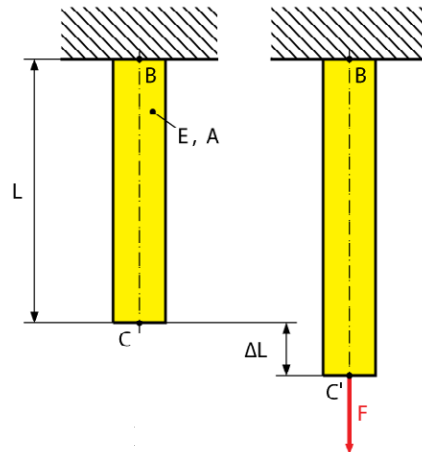


Fig. 2.18

Let us consider a homogeneous isotropic member BC of length L , cross-sectional area A , and Young's modulus E subjected to the centric axial force F , see Fig. 2.18. If the resulting normal stress $\sigma_x = N_{(x)}/A = F/A$ does not exceed the proportional limit stress and applying Saint-Venant's principle we can then apply Hooke's law

$$\sigma_x = E\varepsilon_x \quad \text{or} \quad \varepsilon_x = \frac{\sigma_x}{E} \quad (2.12)$$

And substituting for the normal stress $\sigma_x = N_{(x)}/A = F/A$ we have

$$\varepsilon_x = \frac{N_{(x)}}{EA} = \frac{F}{EA} \quad (2.13)$$

Recalling the definition of normal strain, equation (2.1) we get

$$\Delta L = \varepsilon_x L \quad (2.14)$$

and substituting equation(2.13) into equation (2.14) we have

$$\Delta L = \frac{N_{(x)}L}{EA} = \frac{FL}{EA} \quad (2.15)$$

Now we can conclude that the application of this equation: *Equation (2.15) may be used only if the rod is homogeneous (constant E), has a uniform cross-sectional area A , and is loaded at both ends.* If the member is loaded at any other point or is composed from several different homogeneous parts having different cross-sectional areas we must apply the division into parts satisfying the previous conclusion. Denoted $N_{i(x)}$, E_i , A_i , L_i the internal normal force, Young's modulus, cross-sectional area and length corresponding to the part i respectively. Then the total elongation is the sum of individual elongations (principle of superposition):

$$\Delta L = \sum_{i=1}^n \Delta L_i = \sum_{i=1}^n \frac{N_{i(x)} L_i}{E_i A_i} \quad (2.16)$$

In the case of variable cross-sectional area, as in Fig. 2.4, the strain depends on the position of the arbitrary point Q , therefore we must apply equation (2.2) for the strain computation. After some mathematical manipulation we have the total elongation of the member

$$\Delta L = \int_{(L)} \frac{N_{(x)}}{EA} dx \quad (2.17)$$

Until now we could solve problems starting with the free body diagram, and subsequently determine the reactions from equilibrium equations. Recalling the method of sections in (chapter 2.2) we can compute internal forces at any arbitrary section, allowing us to then proceed with computing stresses, strains and deformations. But many engineering problems can not be solved by the approach of statics alone.

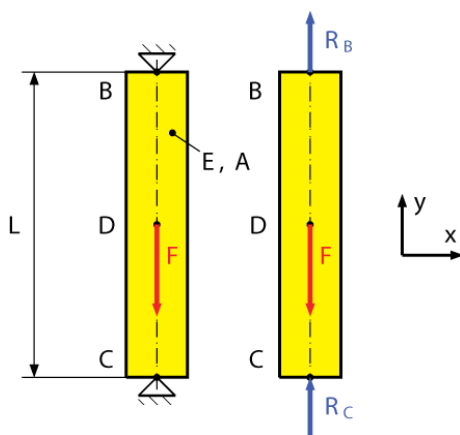


Fig. 2.19

For simplicity, let us consider a simple problem, see Fig. 2.19. Using statics we cannot solve the problem through equilibrium equations. The main difficulty in this problem is that the number of unknown reactions is greater than the number of equilibrium equations. From a mathematical point of view the problem is ill-conditioning. For our case we obtain one equilibrium equation as

$$\sum F_x = 0 : R_C - F + R_B = 0 \quad (2.18)$$

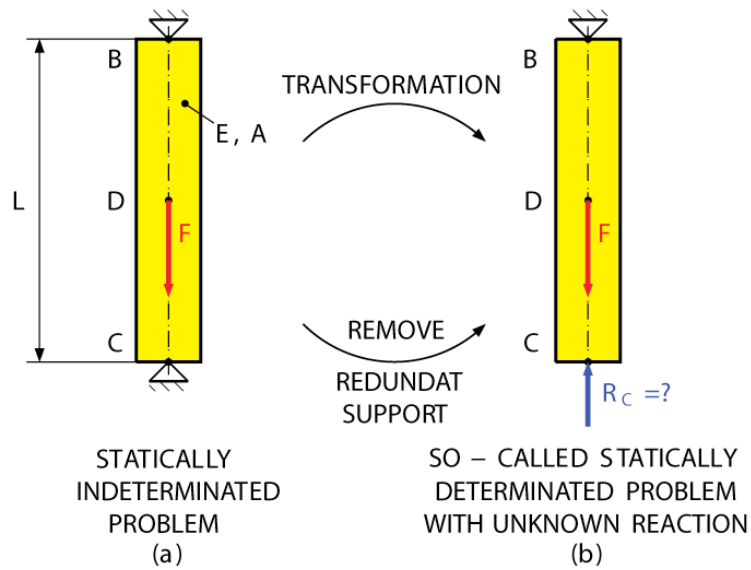


Fig. 2.20

There are two unknown reactions in equation (2.18). Problems of this type are called *statically indeterminate problems*.

The Wake

the only emission we want to leave behind

Low-speed Engines Medium-speed Engines Turbochargers Propellers Propulsion Packages PrimeServ

The design of eco-friendly marine power and propulsion solutions is crucial for MAN Diesel & Turbo. Power competencies are offered with the world's largest engine programme – having outputs spanning from 450 to 87,220 kW per engine. Get up front! Find out more at www.mandieselturbo.com

Engineering the Future – since 1758.

MAN Diesel & Turbo

Click on the ad to read more

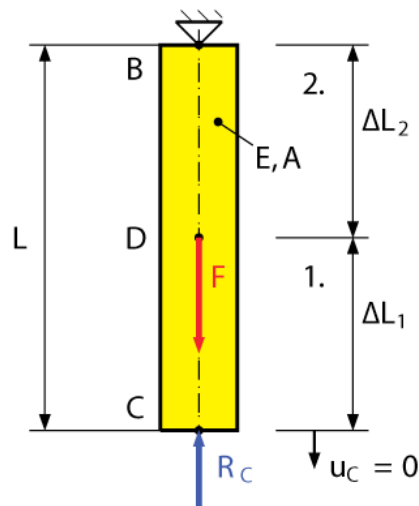


Fig. 2.21

To overcome the static indeterminacy we need to complete the system of equilibrium equations with relations involving deformations by considering the geometry of the problem. These additional relations are called *deformation conditions*. For practical solution let us consider the following transformation in Fig. 2.20. The problem presented is exactly the same as the problem in Fig. 2.19. This problem is statically indeterminate to the first degree. Removing the redundant support at point C and replacing it with the unknown reaction R_c we obtain the so-called statically indeterminate problem with unknown reaction, see Fig. 2.20(b). Now our task is to receive the same response for the statically indeterminate problem as in the original statically indeterminate problem. To get the same response of the structure we need to impose the deformation condition for point C , that the displacement for this point is equal to zero, see Fig. 2.21, or mathematically

$$u_C = 0 \quad (2.19)$$

This condition (2.19) coincides with the total elongation of the member also equal to zero. We then have:

$$u_C = \Delta L = 0 \quad (2.20)$$

The member presented in Fig. 2.21 can be divided into two homogeneous parts. Therefore the total elongation is a sum of individual elongation, equation (2.16), i.e. $\Delta L = \Delta L_1 + \Delta L_2$. Then we have

$$\Delta L = \frac{N_{1(x)}L_1}{EA} + \frac{N_{2(x)}L_2}{EA} = 0 \quad (2.21)$$

Both normal forces $N_{1(x)} = -R_C$, $N_{2(x)} = F - R_C$ are functions of unknown reaction R_C . Solving equation (2.21) we obtain the value of reaction R_C . We can then continue by solving in the usual way for statically determinate problems.

2.8 Problems Involving Temperature Changes

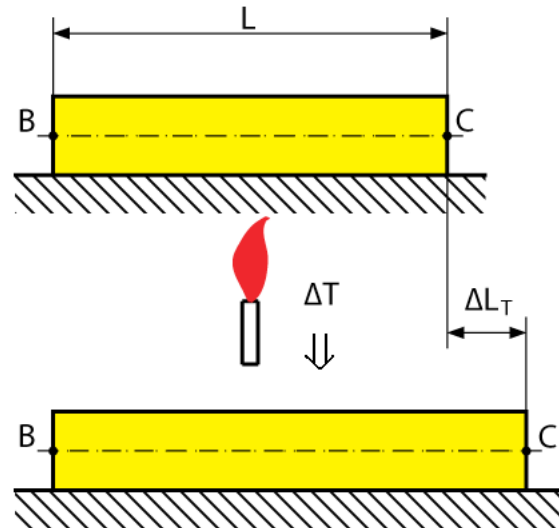


Fig. 2.22

In the previous discussions we assumed constant temperature as the member was being loaded. Let us now consider a homogeneous rod BC with the constant cross-sectional area A and the initial length L , see Fig. 2.22. If the temperature of the rod grows by ΔT then we will observe the elongation of the rod by ΔL_T , see Fig. 2.22. This elongation is proportional to the temperature increase ΔT and the initial length L . Using basic physics we have

$$\Delta L_T = \alpha(\Delta T)L \quad (2.22)$$

where α is the *coefficient of thermal expansion*. The thermal strain ε_T is associated with the aforementioned elongation ΔL_T , i.e. $\varepsilon_T = \Delta L_T/L$. Then we have

$$\varepsilon_T = \alpha(\Delta T) \quad (2.23)$$

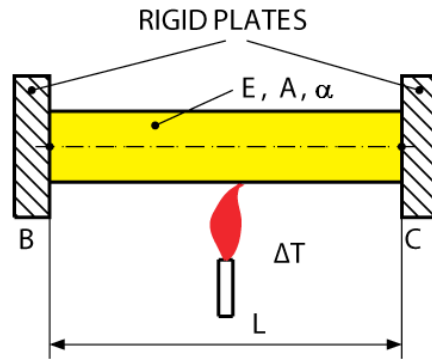


Fig. 2.23

In this case there is no stress in a rod. We can prove this very easily by applying the method of sections and writing equilibrium equations.

SMS from your computer
 ...Sync'd with your Android phone & number

FREE
 30 days trial!

Go to

BrowserTexting.com

and start texting from your computer!

BrowserTexting

The advertisement shows a laptop screen on the left displaying a text message conversation with 'Elias Naur'. On the right is an HTC smartphone displaying the same text messages. A blue double-headed arrow connects the laptop and the phone, indicating synchronization. The laptop screen also shows a list of contacts including 'Annamaria Jansen', 'Anders Samuelson', 'Andreas Johnson', 'Andrew McDonald', 'Anja Petersen', 'Anja Oksanen', 'Anna Hide', 'Anna Skovhede', 'Anne Croft', 'Anne Naur', 'Annette Tyhonen', 'Arne McPherson', 'Aske Pind Uhdersup', and 'Kamahan Mahmood'.

Click on the ad to read more

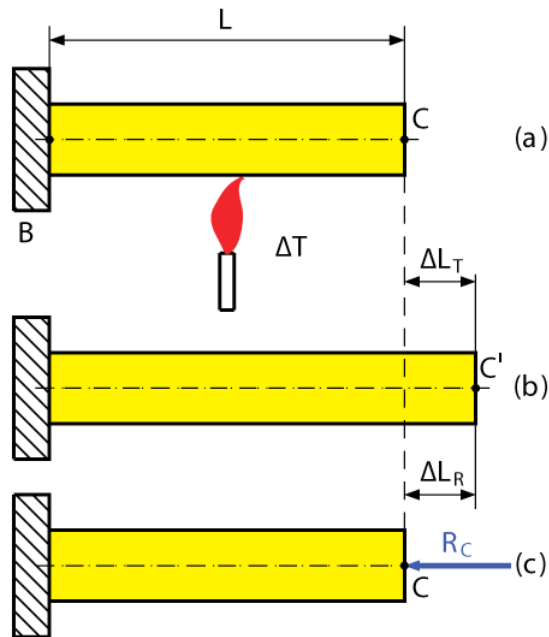


Fig. 2.24

By modify the previous rod by placing it between two rigid plates and subjecting it to a temperature change of ΔT we will observe no elongation because of the fixed supports at its ends. We know that this problem is statically indeterminate due to the supports at each end. Let us then transform the problem into the so-called statically determinate problem. Removing the support at point C and replace it by unknown reaction R_C . Now we can apply the principle of superposition in the following way. Firstly, we heat the rod by ΔT , see Fig. 2.24(a), then we can observe the elongation $\Delta L_T = \alpha(\Delta T)L$, see Fig. 2.24(b). Secondly, we push the rod by the reaction R_C back to its initial length, see Fig. 2.24(c). The effect of pushing is the opposite of elongation ΔL_{R_C} . Applying the formulas (2.22) and (2.15) we have

$$\Delta L_T = \alpha(\Delta T)L \quad \text{and} \quad \Delta L_{R_C} = \frac{R_C L}{EA} \quad (2.24)$$

Expressing the condition that the total elongation must be zero, we get

$$\Delta L = \Delta L_T + \Delta L_{R_C} = \alpha(\Delta T)L + \frac{R_C L}{EA} = 0 \quad (2.25)$$

This equation represents the deformation condition. And we can compute the reaction as

$$R_C = -EA\alpha(\Delta T) \quad (2.26)$$

and corresponding stress

$$\sigma_x = \frac{N(x)}{A} = \frac{R_C}{A} = -E\alpha(\Delta T) \quad (2.27)$$

2.9 Trusses

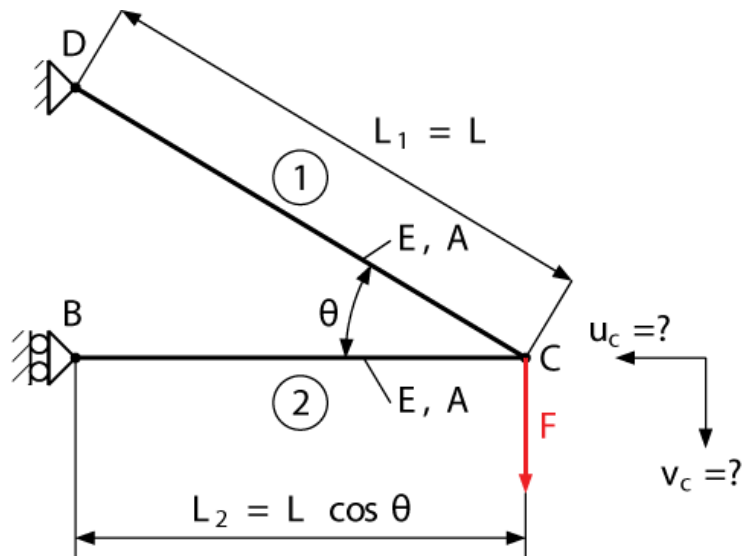


Fig. 2.25

The truss is a structure consisting of several slender members (rods, bars) that are subjected to axial loading only. The simple truss structure is presented in Fig. 2.25. This truss consists of two bars of the same cross-sectional area A and Young's modulus E . The truss is loaded by a vertical force F . Our task is to compute the vertical and horizontal displacements of joint C . Applying the methods of statics we can determine axial forces in each bar: $N_1 = F/\sin \theta$, $N_2 = F/\tan \theta$. Consequently, we can determine elongations for individual bars using equation (2.15)

$$\Delta L_1 = \frac{N_1 L_1}{EA} = \frac{F L_1}{EA \sin \theta} \quad \text{and} \quad \Delta L_2 = \frac{N_2 L_2}{EA} = \frac{F L_2}{EA \tan \theta} \tag{2.28}$$

The deformed configuration can be founded by drawing two circles with centres at joints B and D with the following radii, see Fig. 2.26

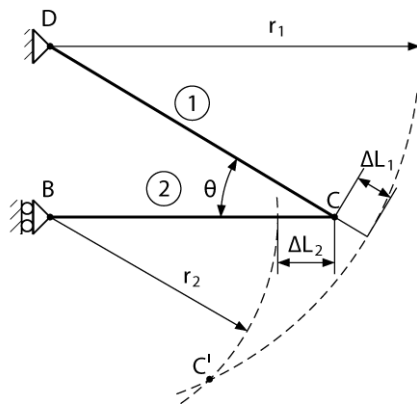


Fig. 2.26

$$r_1 = L_1 + \Delta L_1 = L_1 \left(1 + \frac{F}{EA \sin \theta} \right)$$

$$r_2 = L_2 - \Delta L_2 = L_2 \left(1 - \frac{F}{EA \tan \theta} \right)$$

The deformations are relatively small, therefore we can replace the circles with tangents perpendicular to the undeformed bars, see Fig. 2.27. One can then compute the horizontal and vertical displacements as follows:

$$u_C = \Delta L_2 = \frac{F L_2}{EA \tan \theta}$$

$$v_C = \Delta L_1 \sin \theta + \frac{\Delta L_2 + \Delta L_1 \cos \theta}{\tan \theta} = \frac{F L_1}{EA \sin^2 \theta} + \frac{F L_2}{EA \tan^2 \theta} \tag{2.29}$$

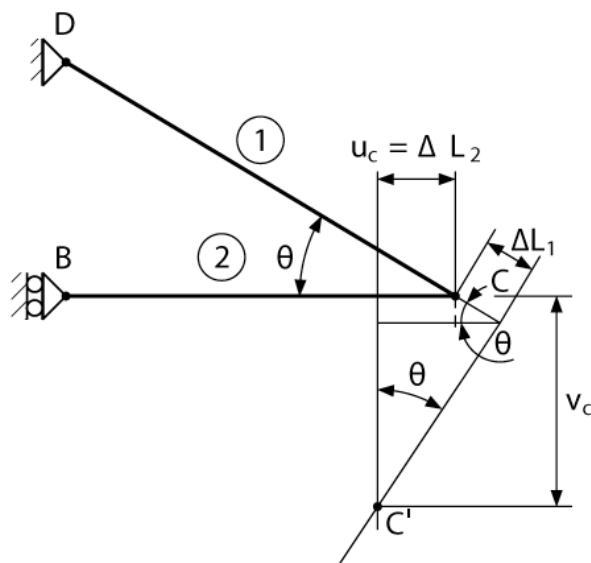


Fig. 2.27 Vertical and horizontal displacements

2.10 Examples, Solved and Unsolved Problems

Problem 2.1

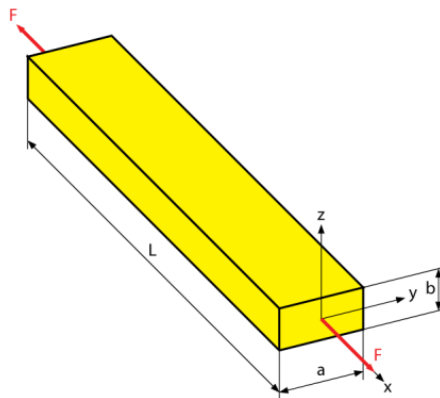


Fig. 2.28

A steel bar has the following dimensions: $a = 100 \text{ mm}$, $b = 50 \text{ mm}$, $L = 1500 \text{ mm}$, shown in Fig. 2.28. If an axial force of $F = 80 \text{ kN}$ is applied to the bar, determine the change in its length and the change in the dimensions of its cross-section after the load is applied. Assume that the material behaves elastically, where the Young's modulus for steel is $E = 200 \text{ GPa}$ and Poisson's ratio $\nu = 0.32$.

Solution

The normal stress in the bar is

$$\sigma_x = \frac{F}{A} = \frac{F}{ab} = \frac{80(10^3) \text{ N}}{(0.1 \text{ m})(0.05 \text{ m})} = 16.0 \times 10^6 \text{ Pa} = 16.0 \text{ MPa}.$$

The strain in the x direction is

$$\varepsilon_x = \frac{\sigma_x}{E} = \frac{16 \times 10^6 \text{ Pa}}{200 \times 10^9 \text{ Pa}} = 80 \times 10^{-6}.$$

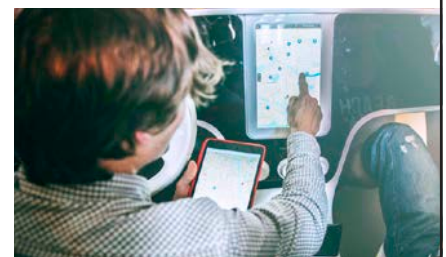
The axial elongation of the bar then becomes

$$\Delta L_x = \varepsilon_x L = \frac{\sigma_x}{E} L = \frac{FL}{abE} = (80 \times 10^{-6}) \times 1.5 \text{ m} = 120 \mu\text{m}.$$

**YOUR WORK AT TOMTOM WILL
BE TOUCHED BY MILLIONS.
AROUND THE WORLD. EVERYDAY.**

Join us now on www.TomTom.jobs

follow us on **LinkedIn**



#ACHIEVEMORE

TOMTOM 



Using Eq. (2.6) for the determination of Poisson's ratio, where $\nu = 0.32$ as given for steel, the contraction strain in the y and z direction are

$$\varepsilon_y = \varepsilon_z = -\nu\varepsilon_x = -0.32(80 \times 10^{-6}) = -25.6 \mu\text{m/m}.$$

Thus the changes in the dimensions of cross-section are given by

$$\Delta L_y = \varepsilon_y L_y = -\nu\varepsilon_x a = -\nu a \frac{\sigma_x}{E} = -\nu a \frac{F}{abE}$$

$$\Delta L_y = -\frac{F\nu}{bE} = -2.56 \mu\text{m}$$

$$\Delta L_z = \varepsilon_z L_z = -\nu\varepsilon_x b = -\nu b \frac{\sigma_x}{E} = -\nu b \frac{F}{abE}$$

$$\Delta L_z = -\frac{F\nu}{aE} = -1.28 \mu\text{m}.$$

Problem 2.2

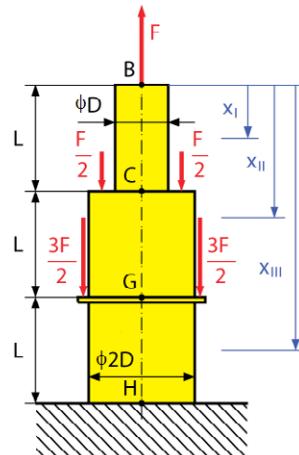


Fig. 2.29

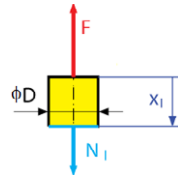
A composite steel bar shown in Fig. 2.29 is made from two segments, BC and CH, having circular cross-section with a diameter of $D_{BC} = D$ and $D_{CH} = 2D$. Determine the diameter D , if we have an allowable stress of $\sigma_{All} = 147 \text{ MPa}$ and the applied load is $F = 20 \text{ kN}$.

Solution

We can divide the bar into three parts (BC, CG and GH) which have constant cross-section area and constant loading.

Stress and Equilibrium for part BC

$$x_I \in \langle 0, L \rangle$$

Solution of normal (axial) load N_I

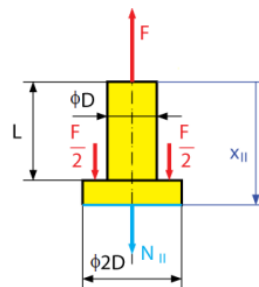
$$\sum F_{ix_I} = 0: \quad F - N_I = 0 \quad \Rightarrow \quad N_I = F = 20 \text{ kN}$$

Stress in the part BC

$$\sigma_I = \frac{N_I}{A_I} = \frac{F}{\frac{\pi D^2}{4}} = \frac{4F}{\pi D^2} = \frac{4 \times 20000 \text{ N}}{\pi D^2} = 25464.8 \frac{1}{D^2}$$

Equilibrium and stress in part CG

$$x_{II} \in \langle L, 2L \rangle$$

Solution of normal (axial) load N_{II}

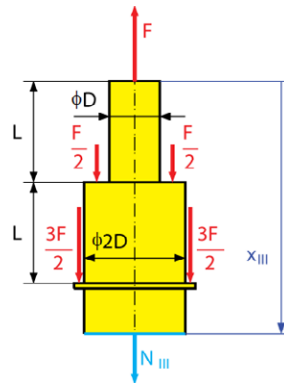
$$\sum F_{ix_{II}} = 0: \quad F - \frac{F}{2} - \frac{F}{2} - N_{II} = 0 \quad \Rightarrow \quad N_{II} = 0$$

Stress in part BC

$$\sigma_I = \frac{N_I}{A_I} = \frac{F}{\frac{\pi D^2}{4}} = \frac{4F}{\pi D^2} = \frac{4 \times 20000 \text{ N}}{\pi D^2} = 25464.8 \frac{1}{D^2}$$

Equilibrium of part and stress in part GH

$$x_{III} \in \langle 2L, 3L \rangle$$



Solution of normal (axial) load N_{III}

$$\sum F_{ix_{III}} = 0: \quad F - \frac{F}{2} - \frac{F}{2} - \frac{3F}{2} - \frac{3F}{2} - N_{III} = 0 \quad \Rightarrow \quad N_{III} = -3F$$

$$N_{III} = -3F = -3 \times 20000 \text{ N} = -90000 \text{ N}$$

Brain power

By 2020, wind could provide one-tenth of our planet's electricity needs. Already today, SKF's innovative know-how is crucial to running a large proportion of the world's wind turbines.

Up to 25 % of the generating costs relate to maintenance. These can be reduced dramatically thanks to our systems for on-line condition monitoring and automatic lubrication. We help make it more economical to create cleaner, cheaper energy out of thin air.

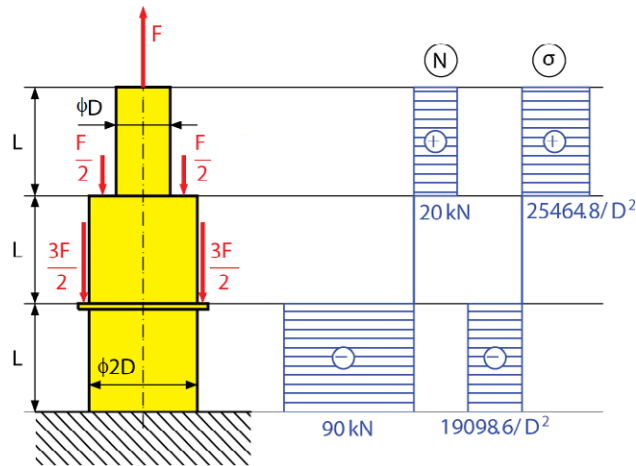
By sharing our experience, expertise, and creativity, industries can boost performance beyond expectations. Therefore we need the best employees who can meet this challenge!

The Power of Knowledge Engineering

Plug into The Power of Knowledge Engineering.
Visit us at www.skf.com/knowledge

Stress in part CD

$$\sigma_{III} = \frac{N_{III}}{A_{III}} = \frac{-3F}{\frac{\pi(2D)^2}{4}} = -\frac{3F}{\pi D^2} = -\frac{3 \times 20000 \text{ N}}{\pi D^2} = -19098.6 \frac{1}{D^2}$$



For all parts, draw the diagram of normal force and stress. The maximum stress is in the first part (BC), which we can compare with the allowable stress and obtain the parameter D

$$\sigma_{MAX} = \sigma_I = \frac{4F}{\pi D^2} \leq \sigma_{All} \Rightarrow D \geq \sqrt{\frac{4F}{\pi \sigma_{All}}}$$

$$D \geq \sqrt{\frac{4 \times 20000 \text{ N}}{\pi \cdot 147 \text{ MPa}}} \Rightarrow D \geq 13.2 \text{ mm}$$

Problem 2.3

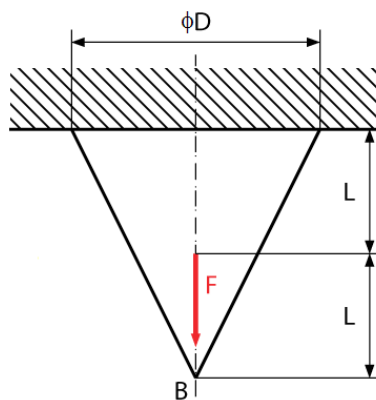


Fig 2.30

Determine the elongation of a conical bar shown in Fig. 2.30 at point B without considering its weight.

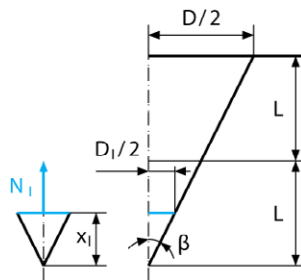
Given by maximum cone diameter of D , length L , modulus of elasticity E and applied force F , Determine the maximum stress in the conical bar.

Solution

The problem is divided into two parts.

Equilibrium of the first part

$$x_1 \in \langle 0, L/2 \rangle$$



We determine the normal force N_1 and normal stress σ_1

Normal force N_1 :

$$\sum F_{ix_1} = 0: \quad N_1(x_1) = 0 \quad \Rightarrow \quad N_1(x_1) = 0$$

Calculate angle β from the geometry of the cone given by diameter D_1 at position x_1

$$\tan \beta = \frac{\frac{D}{2} - \frac{D_1(x_1)}{2}}{x_1} = \frac{\frac{D - D_1(x_1)}{2}}{x_1} \quad \Rightarrow \quad D_1(x_1) = \frac{x_1}{L} D$$

Cross-sectional area (function of position) in the first part is

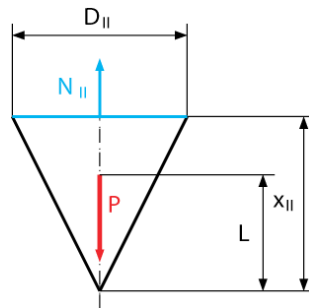
$$A_1(x_1) = \frac{\pi D_1^2}{4} = \frac{\pi}{4} \left(\frac{x_1}{L} D \right)^2 = \frac{\pi D^2}{4} \frac{x_1^2}{L^2}$$

Normal stress σ_1 is as follows

$$\sigma_1(x_1) = \frac{N_1(x_1)}{A_1(x_1)} = \frac{0}{\frac{\pi D^2 x_1^2}{4L^2}} = 0$$

Equilibrium of the second part

$$x_{II} \in \langle L/2, L \rangle$$



We determine the normal force N_{II} and normal stress σ_{II} .

Normal force N_{II} :

$$\sum F_{ix_{II}} = 0: \quad N_{II}(x_{II}) - F = 0 \quad \Rightarrow \quad N_{II}(x_{II}) = F$$

> Apply now

REDEFINE YOUR FUTURE
**AXA GLOBAL GRADUATE
 PROGRAM 2015**

redefining / standards 

agence.cdg. © Photonostop

 **Click on the ad to read more**

Calculation of angle β from geometry and diameter D_{II} at position x_{II}

$$\tan \beta = \frac{D}{L} = \frac{D_{II}(x_{II})}{x_{II}} \quad \Rightarrow \quad D_{II}(x_{II}) = \frac{x_{II}}{L} D$$

Cross-section area (function of position) in second part is

$$A_{II}(x_{II}) = \frac{\pi D_{II}^2}{4} = \frac{\pi}{4} \left(\frac{x_{II}}{L} D \right)^2 = \frac{\pi D^2}{4} \frac{x_{II}^2}{L^2}$$

Normal stress σ_{II} is then

$$\sigma_{II}(x_{II}) = \frac{N_{II}(x_{II})}{A_{II}(x_{II})} = \frac{F}{\frac{\pi D^2 x_{II}^2}{4L^2}} = \frac{4FL^2}{\pi D^2 x_{II}^2}$$

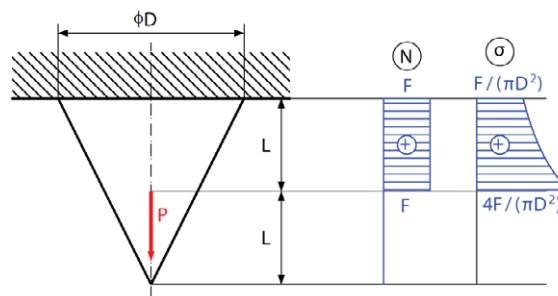


Fig. 2.31

The graphical result of the normal force and stress is shown in the Fig. 2.31.

Elongation is found by summing the elongation of each part using integration, because cross-section area is a function of position in all parts, which is given by

$$\Delta L_B = \Delta L_I + \Delta L_{II} = \int_0^{L/2} \frac{N_I(x_I)}{EA_I(x_I)} dx_I + \int_{L/2}^L \frac{N_{II}(x_{II})}{EA_{II}(x_{II})} dx_{II}$$

$$\Delta L_B = \int_0^{L/2} \frac{0}{EA_I(x_I)} dx_I + \int_{L/2}^L \frac{F}{\pi D^2 \frac{x_{II}^2}{4L^2}} dx_{II}$$

$$\Delta L_B = \frac{4FL^2}{E\pi D^2} \int_{L/2}^L \frac{1}{x_{II}^2} dx_{II} = \frac{4FL^2}{E\pi D^2} \left[-\frac{1}{x_{II}} \right]_{L/2}^L = \frac{4FL^2}{E\pi D^2} \frac{1}{L}$$

$$\Delta L_B = \frac{4FL}{E\pi D^2}$$

Problem 2.4

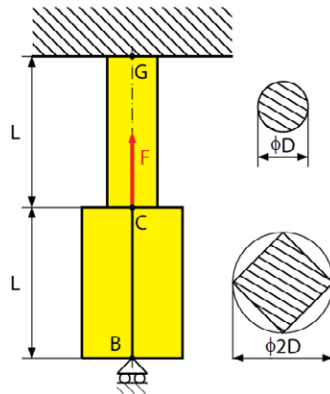


Fig. 2.32

A bar BC and CG of length L is attached to rigid supports at B and G. Part BC have a square cross-section and between point C and G the cross section is circular. What are the stresses in portions BC and CG due to the application of load F at point C in Fig. 2.32. The weight of the bar is neglected. Design the parameter D to accommodate for the given allowable stress σ_{All} . length L, modulus of elasticity E and applied force F are known. Problem is statically indeterminate.

Solution

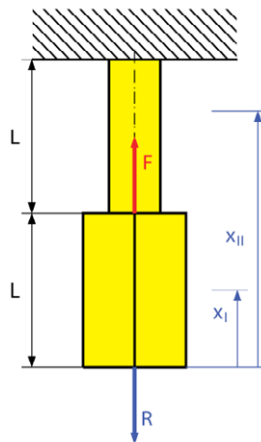


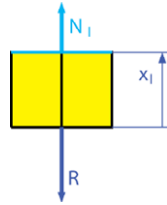
Fig. 2.33

At first, we detach the bar at point B and define a reaction at its location, which will be solved from the deformation condition. (See Fig. 2.33).

The solution is divided into two solutions part BC and CG.

Free-body diagram on portion I (part BC):

$$x_1 \in \langle 0, L \rangle$$



From the equilibrium equation in the first part, we obtain

$$\sum F_{ix_1} = 0: \quad N_1(x_1) - R = 0 \quad \Rightarrow \quad N_1(x_1) = R$$

Solution of cross-section area is given From Pythagoras theorem where we determine the side length of the square:

$$\begin{aligned} (2D)^2 &= a^2 + a^2 \\ A_1 = a^2 &\Rightarrow 4D^2 = 2a^2 &\Rightarrow A_1 = 2D^2 \\ 2D^2 &= a^2 \end{aligned}$$

LIGS University

based in Hawaii, USA

is currently enrolling in the
Interactive Online **BBA, MBA, MSc,**
DBA and PhD programs:

- ▶ enroll **by October 31st, 2014** and
- ▶ **save up to 11%** on the tuition!
- ▶ pay in 10 installments / 2 years
- ▶ Interactive **Online** education
- ▶ visit www.ligsuniversity.com to find out more!

Note: LIGS University is not accredited by any nationally recognized accrediting agency listed by the US Secretary of Education. More info [here](http://www.ligsuniversity.com).



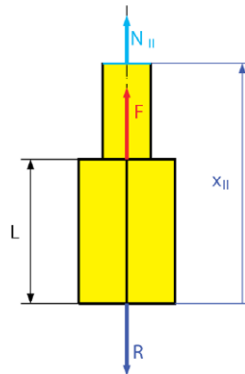


Stress in portion BC is

$$\sigma_I(x_I) = \frac{N_I(x_I)}{A_I(x_I)} = \frac{R}{2D^2}$$

Free-body diagram an portion II (part CG):

$$x_{II} \in \langle L, 2L \rangle$$



From the equilibrium equation in the second part, we obtain

$$\sum F_{ix_{II}} = 0: \quad N_{II}(x_{II}) + F - R = 0 \quad \Rightarrow \quad N_{II}(x_{II}) = R - F$$

Stress in portion CG is

$$\sigma_{II}(x_{II}) = \frac{N_{II}(x_{II})}{A_{II}(x_{II})} = \frac{R - F}{\frac{\pi D^2}{4}} = \frac{4(R - F)}{\pi D^2}$$

We determine the unknown reaction from the deformation condition, total elongation (movement of point B) is equal to zero:

$$\Delta L_B = 0 \quad \Rightarrow \quad \Delta L_B = \Delta L_I + \Delta L_{II} = 0 \quad \Rightarrow \quad \Delta L_I + \Delta L_{II} = 0,$$

from which we have

$$\begin{aligned} \frac{P_I L_I}{E_I A_I} + \frac{P_{II} L_{II}}{E_{II} A_{II}} = 0 & \Rightarrow \frac{RL}{E 2D^2} + \frac{4(R-F)L}{E \pi D^2} = 0 \\ \pi R + 8(R-F) = 0 & \Rightarrow R = \frac{8F}{\pi + 8} \end{aligned}$$

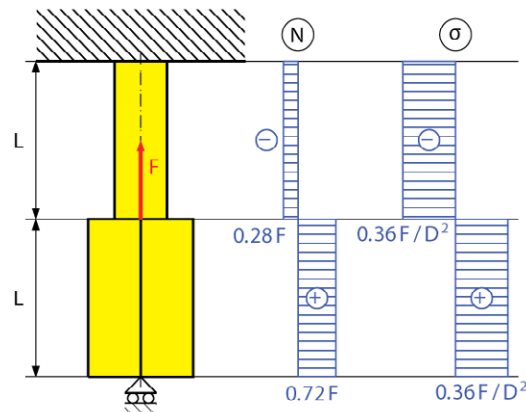


Fig. 2.34

We insert the solved reaction into the result of parts BC and CG,

$$N_I(x_I) = R = \frac{8F}{\pi+8} = 0.72F$$

$$\sigma_I(x_I) = \frac{N_I(x_I)}{A_I(x_I)} = \frac{8F}{(\pi+8)2D^2} = 0.36 \frac{F}{D^2}$$

$$N_{II}(x_{II}) = R - F = \frac{8F}{\pi+8} - F = -\frac{\pi F}{\pi+8} = -0.28F$$

and draw the diagram of normal forces and stresses for both portions, which is shown in the Fig. 2.34

Design of parameter D

The maximum (absolute value) of stresses is the same for both portions, we compare them with the allowable stress and we get the designed parameter D:

$$\sigma_{\text{MAX}} = 0.36 \frac{F}{D^2} \leq \sigma_{\text{All}} \quad \Rightarrow \quad D \geq \sqrt{\frac{0.36F}{\sigma_{\text{All}}}}$$

Problem 2.5

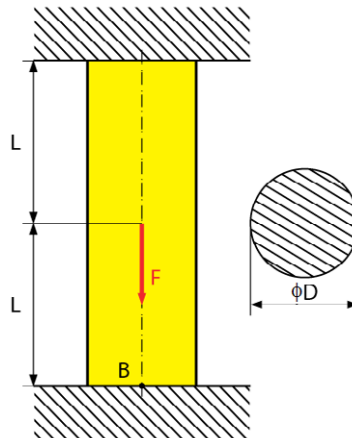


Fig. 2.35

In Fig. 2.35, a bar of length $2L$ with uniform circular cross-section area and made of the same material with a modulus of elasticity E , is subjected to an applied force F . determine the stress in the bar. Consider the weight of bar (density ρ and gravity g are known).

TURN TO THE EXPERTS FOR SUBSCRIPTION CONSULTANCY

Subscribe is one of the leading companies in Europe when it comes to innovation and business development within subscription businesses.

We innovate new subscription business models or improve existing ones. We do business reviews of existing subscription businesses and we develop acquisition and retention strategies.

Learn more at [linkedin.com/company/subscribe](https://www.linkedin.com/company/subscribe) or contact Managing Director Morten Suhr Hansen at mha@subscribe.dk

SUBSCR✓**IBE** - to the future

Solution

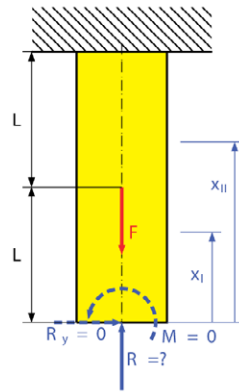


Fig. 2.36

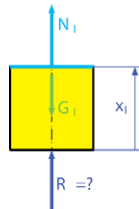
Problem is statically indeterminate and for the solution we use the deformation condition at point B.

First step of solution is to substitute an unknown reaction at point B (see Fig. 2.36).

Because the problem is in pure tension, the reaction R_y and moment M are zero, reaction R is non-zero.

Solution of this problem is divided into two parts.

$$x_I \in \langle 0, L \rangle$$



Equilibrium of first part

$$\sum F_{ix_I} = 0: \quad N_I(x_I) + R - G_I = 0 \quad \Rightarrow \quad N_I(x_I) = G_I - R$$

where G_I is gravitational load of first part, defined by

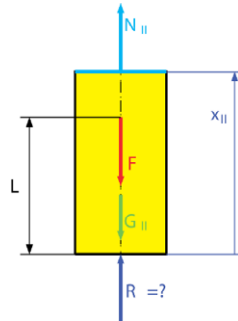
$$G_I = mg = \rho Vg = \rho g A_I x_I$$

Normal force and stress is gathered by

$$N_I(x_I) = \rho g A_I x_I - R$$

$$\sigma_I(x_I) = \frac{N_I(x_I)}{A_I(x_I)} = \frac{\rho g A_I x_I - R}{A_I} = \rho g x_I - \frac{R}{A}$$

$$x_{II} \in \langle L, 2L \rangle$$



Equilibrium at the second part, is given by

$$\sum F_{ix_{II}} = 0: \quad N_{II}(x_{II}) + F - R - G_{II} = 0 \quad \Rightarrow \quad N_{II}(x_{II}) = F + G_{II} - R$$

Normal force and stress is as follows

$$N_{II}(x_{II}) = F + \rho g A_{II} x_{II} - R = F + \rho g A x_{II} - R$$

$$\sigma_{II}(x_{II}) = \frac{N_{II}(x_{II})}{A_{II}(x_{II})} = \frac{F + \rho g A x_{II} - R}{A} = \frac{F}{A} + \rho g x_{II} - \frac{R}{A}$$

Deformation condition at point A

Total elongation at point A is equal to zero, which is consisting of the first part of the bar ΔL_I and second part ΔL_{II} . For solution of each part we used the integral form because normal force is a function of position. Unknown reaction R after calculation becomes

$$\Delta L_A = \Delta L_I + \Delta L_{II} = 0 \quad \Rightarrow \quad \frac{P_I L_I}{E_I A_I} + \frac{P_{II} L_{II}}{E_{II} A_{II}} = 0$$

$$\int_0^L \frac{(\rho g A x_I - R)L}{EA} dx_I + \int_L^{2L} \frac{(F + \rho g A x_{II} - R)L}{EA} dx_{II} = 0$$

$$2\rho g AL + F = 2R \quad \Rightarrow \quad R = \rho g AL + \frac{F}{2}$$

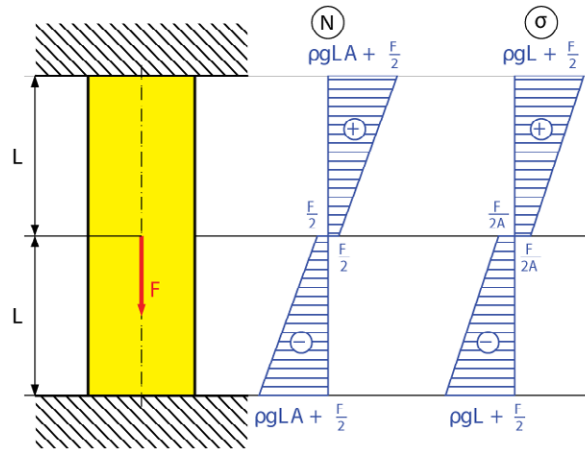


Fig. 2.37

We insert the result of reaction R into the function of normal force and stress for both parts and the diagram for force and stress is shown in Fig. 2.37.

$$N_I(x_I) = \rho g A x_I - \left(\rho g A L + \frac{F}{2} \right) = \rho g A (x_I - L) - \frac{F}{2}$$

$$\sigma_I(x_I) = \frac{N_I(x_I)}{A_I(x_I)} = \frac{\rho g A_1 x_I - R}{A_1} = \rho g (x_I - L) - \frac{F}{2A}$$

$$N_{II}(x_{II}) = F + \rho g A x_{II} - R = F + \rho g A x_{II} - \left(\rho g A L + \frac{F}{2} \right) = \frac{F}{2} + \rho g A (x_{II} - L)$$

$$\sigma_{II}(x_{II}) = \frac{N_{II}(x_{II})}{A_{II}(x_{II})} = \frac{F}{2A} + \rho g (x_{II} - L)$$

Problem 2.6

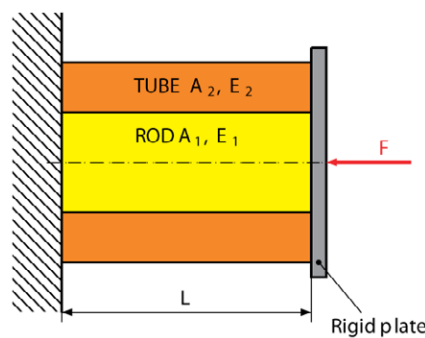
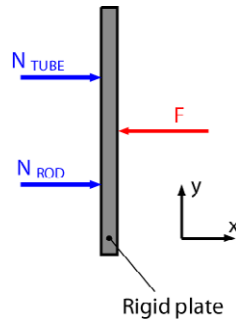


Fig. 2.38

A rod of length L , cross-sectional area A_1 , and modulus of elasticity E_1 has been placed inside a tube with the same length L , but of differing cross-sectional area A_2 and modulus of elasticity E_2 (Fig. 2.38). What is the deformation of the rod and tube when F is applied to the end of the plate as shown?

Solution

The axial force in the rod and in the tube is denoting by N_{ROD} and N_{TUBE} , respectively. we draw a free-body diagram for the rigid plate in Fig. 2.39:

**Fig. 2.39**

$$\sum F_{ix} = 0: \quad N_{\text{TUBE}} + N_{\text{ROD}} - F = 0 \quad \Rightarrow \quad N_{\text{TUBE}} + N_{\text{ROD}} = F \quad (\text{a})$$

The problem is statically indeterminate. However, the geometry of the problem shows that the deformation DL_{ROD} and DL_{TUBE} of the rod and tube must be equal:

$$\Delta L_{\text{TUBE}} = \Delta L_{\text{ROD}} \quad \Rightarrow \quad \frac{N_{\text{TUBE}} L_{\text{TUBE}}}{E_{\text{TUBE}} A_{\text{TUBE}}} = \frac{N_{\text{ROD}} L_{\text{ROD}}}{E_{\text{ROD}} A_{\text{ROD}}}$$

$$N_{\text{TUBE}} = N_{\text{ROD}} \frac{E_{\text{TUBE}} A_{\text{TUBE}}}{E_{\text{ROD}} A_{\text{ROD}}} \quad (\text{b})$$

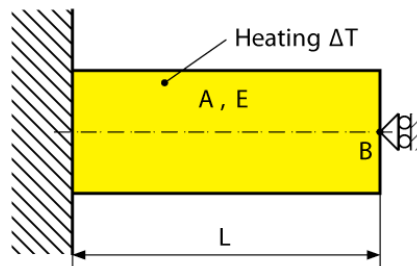
Equation (a) and (b) can be solved simultaneously for N_{ROD} and N_{TUBE} by:

$$N_{\text{ROD}} \frac{E_{\text{TUBE}} A_{\text{TUBE}}}{E_{\text{ROD}} A_{\text{ROD}}} + N_{\text{ROD}} = F$$

$$N_{\text{ROD}} \left(\frac{E_{\text{TUBE}} A_{\text{TUBE}}}{E_{\text{ROD}} A_{\text{ROD}}} + 1 \right) = F$$

$$N_{\text{ROD}} = \frac{F}{\left(\frac{E_{\text{TUBE}} A_{\text{TUBE}}}{E_{\text{ROD}} A_{\text{ROD}}} + 1 \right)}$$

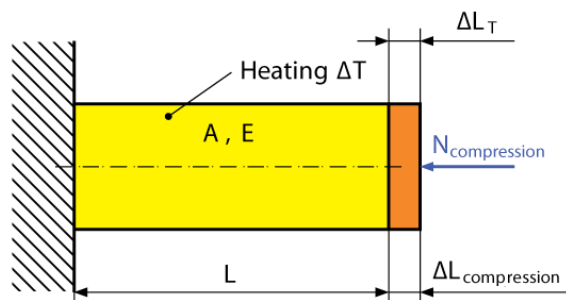
$$N_{\text{TUBE}} = \frac{E_{\text{TUBE}} A_{\text{TUBE}}}{E_{\text{ROD}} A_{\text{ROD}}} \frac{F}{\left(\frac{E_{\text{TUBE}} A_{\text{TUBE}}}{E_{\text{ROD}} A_{\text{ROD}}} + 1 \right)}$$

Problem 2.7**Fig. 2.40**

Determine the value of stress in the steel bar shown on Fig. 2.40 when the temperature change of the bar is $\Delta T = 30\text{ }^\circ\text{C}$. Assume a value of $E = 200\text{ GPa}$ and $\alpha = 12 \times 10^{-6}\text{ }1/^\circ\text{C}$ for steel.

Solution

We first determine the reaction at the support. Since the problem is statically indeterminate, we detach the bar from its support at B.

**Fig. 2.41**

The corresponding deformation from temperature exchange (Fig. 2.41) is

$$\Delta L_T = \alpha \Delta T L$$

Applying the unknown force $N_{\text{compression}}$ at the end of the bar at B (Fig. 2.41). We use eq. (2.15) to express the corresponding deformation $\Delta L_{\text{compression}}$

$$\Delta L_{\text{compression}} = \frac{N_{\text{compression}} L}{EA}$$

Total deformation of the bar must be zero at point B, from which we have the following deformation condition

$$\Delta L_{\text{compression}} = \Delta L_T,$$

from this we obtain $N_{\text{compression}}$

$$N_{\text{compression}} = \alpha \Delta T EA.$$

Stress in the bar is then given by

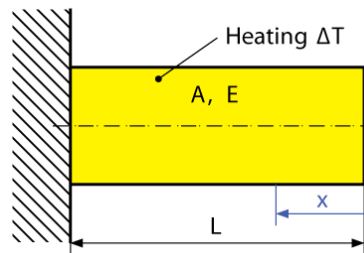
$$\sigma = \frac{N_{\text{compression}}}{A} = \frac{\alpha \Delta T EA}{A} = \alpha \Delta T E = 12 \times 10^{-6} \text{ 1/}^\circ\text{C} \times 30 \text{ }^\circ\text{C} \times 200 \times 10^9 \text{ Pa} = 72 \text{ MPa}.$$



“I studied English for 16 years but...
...I finally learned to speak it in just six lessons”
Jane, Chinese architect

ENGLISH OUT THERE

Click to hear me talking before and after my unique course download

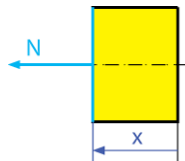
Problem 2.8**Fig. 2.42**

Determine the stress of the aluminum bar $L = 500 \text{ mm}$ shown in Fig. 2.42. when its temperature changes by $\Delta T = 50 \text{ }^\circ\text{C}$. Use the value $E = 70 \text{ GPa}$ and $\alpha = 22.2 \times 10^{-6} \text{ } 1/^\circ\text{C}$ for aluminum.

Solution

We determine the elongation of the bar from temperature exchange from the following equation

$$x \in \langle 0, L \rangle$$

**Fig. 2.43**

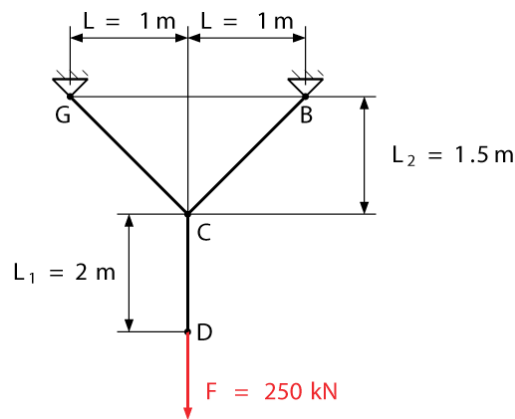
$$\Delta L = \Delta L_T = \alpha \Delta T L = 22.2 \times 10^{-6} \text{ } 1/^\circ\text{C} \times 40 \text{ }^\circ\text{C} \times 500 \text{ mm} = 0.444 \text{ mm}$$

We divide the bar into one component part shown in Fig. 2.43. From equilibrium equation in this part we find the unknown normal force:

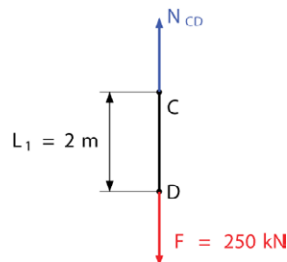
$$\sum F_{ix} = 0: \quad N(x) = 0$$

Stress in the aluminum bar we describe by

$$\sigma = \frac{N}{A} = \frac{0}{A} = 0 \text{ Pa}$$

Problem 2.9**Fig. 2.44**

The linkage in Fig. 2.44 is made of three 304 stainless members connected together by pins, each member has a cross-sectional area of $A = 1000 \text{ mm}^2$. If a vertical force $F = 250 \text{ kN}$ is applied to the end of the member at D, Determine the stresses of all members and the maximum stress σ_{MAX} .

Solution**Fig. 2.45**

First we disconnected the member CD and draw a free-body diagram (shown in Fig. 2.45) We then solve for the force N_{CD} by the following equilibrium equation

$$\sum F_{iy} = 0: \quad N_{\text{CD}} - F = 0 \quad \Rightarrow \quad N_{\text{CD}} = F = 250 \text{ kN}$$

Other normal forces N_{AC} and N_{BC} we determined from equilibrium at point C (shown in Fig. 2.46), given by:

$$\tan \alpha = \frac{L}{L_2} = \frac{1.0 \text{ m}}{1.5 \text{ m}} = 0.666 \quad \Rightarrow \quad \alpha = 33.69^\circ$$

In the x direction

$$\sum F_{ix} = 0: \quad -N_{GC} \sin \alpha + N_{BC} \sin \alpha = 0 \quad \Rightarrow \quad -N_{GC} + N_{BC} = 0$$

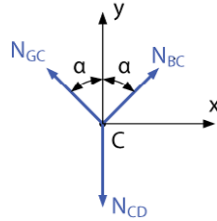


Fig. 2.46

$$N_{BC} = N_{GC}$$

In the y direction

$$\sum F_{iy} = 0: \quad N_{GC} \cos \alpha + N_{BC} \cos \alpha - N_{CD} = 0$$

$$2N_{BC} \cos \alpha = N_{CD} = F \quad \Rightarrow \quad N_{BC} = \frac{F}{2 \cos \alpha} = \frac{250 \text{ kN}}{2 \cos 33.69^\circ} = 150.23 \text{ kN}$$

$$N_{GC} = N_{BC} = 150.23 \text{ kN}$$

Stresses in the members are

$$\sigma_{GC} = \frac{N_{GC}}{A} = \frac{150.23 \cdot 10^3 \text{ N}}{1000 \text{ mm}^2} = 150.23 \text{ MPa}$$

$$\sigma_{BC} = \frac{N_{BC}}{A} = \frac{150.23 \cdot 10^3 \text{ N}}{1000 \text{ mm}^2} = 150.23 \text{ MPa}$$

$$\sigma_{CD} = \frac{N_{CD}}{A} = \frac{250 \cdot 10^3 \text{ N}}{1000 \text{ mm}^2} = 250 \text{ MPa}$$

Maximum value of stress is at link CD

$$\sigma_{\text{MAX}} = \sigma_{CD} = 250 \text{ MPa}$$

Problem 2.10

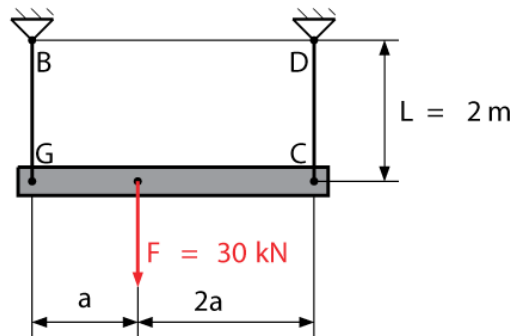


Fig. 2.47

The assembly consists of two titanium rods and a rigid beam AC in Fig. 2.47. The cross section area is $A_{GB} = 60 \text{ mm}^2$ and $A_{CD} = 45 \text{ mm}^2$. The force is applied at a $a = 0.5 \text{ m}$. Determine the stress at rod GB and CD; if a the vertical force is equal to $F = 30 \text{ kN}$.

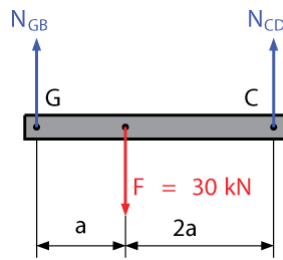
wethrive.net

How to retain your top staff
FIND OUT NOW FOR FREE

DO YOU WANT TO KNOW:

- What your staff really want?
- The top issues troubling them?
- How to make staff assessments work for you & them, painlessly?

Get your free trial
Because happy staff get more done

Solution**Fig. 2.48**

The unknown normal forces in the titanium rod are found from the equilibrium equation of rigid beam GC in Fig. 2.48, given by

$$\sum F_{iy} = 0: \quad N_{GB} + N_{CD} - F = 0$$

$$\sum M_{iB} = 0: \quad N_{CD} 3a - Fa = 0 \quad \Rightarrow \quad N_{CD} = \frac{F}{3} = \frac{30 \text{ kN}}{3} = 10 \text{ kN}$$

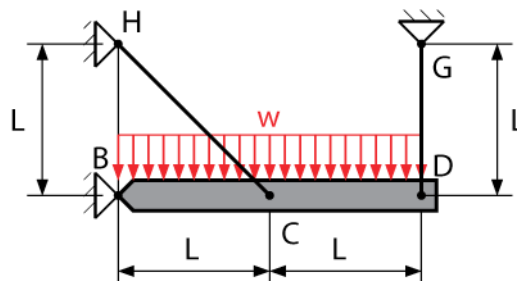
$$N_{GB} = F - N_{CD} = 30 \text{ kN} - 10 \text{ kN} = 20 \text{ kN}$$

$$N_{GB} = 20 \text{ kN}$$

Stress in rod AB and CD is given by the following

$$\sigma_{GB} = \frac{N_{GB}}{A_{GB}} = \frac{20000 \text{ N}}{60 \text{ mm}^2} = 333.3 \text{ MPa}$$

$$\sigma_{CD} = \frac{N_{CD}}{A_{CD}} = \frac{10000 \text{ N}}{45 \text{ mm}^2} = 222.2 \text{ MPa}$$

Problem 2.11**Fig. 2.49**

The rigid bar BD is supported by two links AC and CD in Fig. 2.49. Link CH is made of aluminum ($E_{CH} = 68.9$ GPa) and has a cross-section area $A_{CH} = 14$ mm²; link DG is made of aluminum ($E_{DG} = 68.9$ GPa) and has a cross-section of $A_{DG} = 2 A_{CH} = 280$ mm². For the uniform load $w = 9$ kN/m, determine the deflection at point D and stresses in the link CH and DG.

Solution

Free body diagram of rigid bar BD

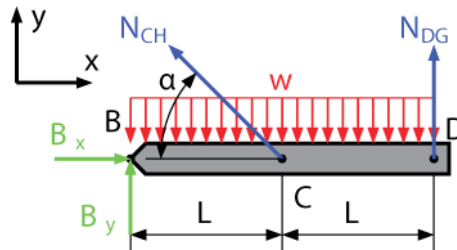


Fig. 2.50

Equilibrium equation of moment at point B in the bar BC (Fig. 2.50), is expressed as

$$\sum M_{iB} = 0: \quad N_{CH}L\sin\alpha + N_{DG}2L - w2LL = 0$$

$$\Rightarrow \quad N_{CH} \frac{\sqrt{2}}{2} + 2N_{DG} = 2wL,$$

(a)

where

$$\tan \alpha = \frac{L}{L} = 1 \quad \Rightarrow \quad \alpha = 45^\circ$$

in equation (a) we have two unknowns. We need a second equation for the solution of normal forces in the links from the deformation condition in Fig. 2.51, from the similar triangles

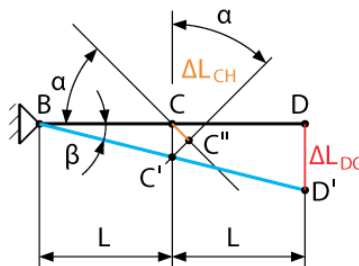


Fig. 2.51

$$\triangle BDD' \approx \triangle BCC'$$

$$\tan \beta = \frac{DD'}{BD} = \frac{CC'}{BC} \Rightarrow \frac{\Delta L_{CH}}{L \sin \alpha} = \frac{\Delta L_{DG}}{2L}$$

In these triangles the angle β are the same from which we have the following equation:

$$\sin \alpha = \frac{\Delta L_{CH}}{CC'} \Rightarrow CC' = \frac{\Delta L_{CH}}{\sin \alpha}$$

$$\Delta L_{CH} = \frac{N_{CH} L_{CH}}{E_{CH} A_{CH}} = \frac{N_{CH} \sqrt{2}L}{EA}$$

$$\Delta L_{DG} = \frac{N_{DG} L_{DG}}{E_{DG} A_{DG}} = \frac{N_{DG} L}{2EA}$$

$$\frac{\Delta L_{CH}}{L \sin \alpha} = \frac{\Delta L_{DG}}{2L} \Rightarrow \frac{N_{CH} \sqrt{2}L}{EA \sqrt{2}} = \frac{N_{DG} L}{2EA} \Rightarrow N_{CH} = \frac{N_{DG}}{4} \quad (b)$$

gaieteye
Challenge the way we run

EXPERIENCE THE POWER OF FULL ENGAGEMENT...

**RUN FASTER.
RUN LONGER..
RUN EASIER...**

**READ MORE & PRE-ORDER TODAY
WWW.GAITEYE.COM**

Solving for the system of equations (a) and (b), we get

$$\frac{N_{DG}}{4} \frac{\sqrt{2}}{2} + 2N_{DG} = 2wL \Rightarrow N_{DG} = \frac{2wL}{\left(\frac{\sqrt{2}}{8} + 2\right)} = 0.92wL$$

$$N_{DG} = 0.92wL = 0.92 \cdot 300\text{N/m} \cdot 1\text{m} = 276 \text{ N}$$

$$N_{CH} = \frac{N_{DG}}{4} = \frac{wL}{2\left(\frac{\sqrt{2}}{8} + 2\right)} = \frac{0.92wL}{4} = 0.23wL$$

$$N_{CH} = 0.23wL = 0.23 \cdot 300\text{N/m} \cdot 1\text{m} = 69 \text{ N}$$

Stress in link CH is

$$\sigma_{CH} = \frac{N_{CH}}{A_{CH}} = \frac{69 \text{ N}}{14 \text{ mm}^2} = 4.93 \text{ MPa}$$

Stress in link DG is

$$\sigma_{DG} = \frac{N_{DG}}{A_{DG}} = \frac{276 \text{ N}}{28 \text{ mm}^2} = 9.86 \text{ MPa}$$

Deflection of point D is given by the following

$$\Delta L_{DG} = \frac{N_{DG} L_{DG}}{E_{DG} A_{DG}} = \frac{0.92wL L}{2EA} = \frac{0.92 \cdot 300\text{N/m} \cdot (1\text{m})^2}{2 \cdot 68.9 \cdot 10^9\text{Pa} \cdot 14 \cdot 10^{-6}\text{m}^2}$$

$$\Delta L_{DG} = 1.43 \cdot 10^{-4}\text{m} = 0.143 \text{ mm}$$

Unsolved problems

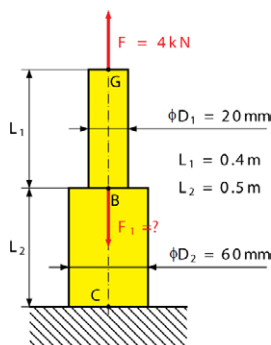


Fig. 2.52

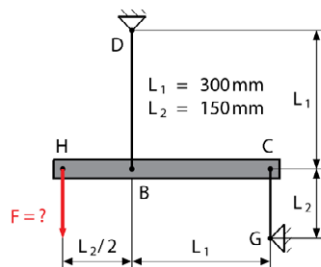


Fig. 2.53

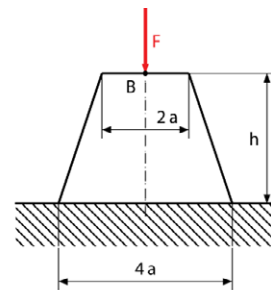


Fig. 2.54

Problem 2.12

Both portions of rod GBC in Fig. 2.52 are made of aluminum for which $E = 70 \text{ GPa}$. Knowing that the magnitude of F is 4 kN , determine (a) the value of F_1 so that the deflection at point A is zero, (b) the corresponding deflection of point B, (c) the value of stress for each portion.

$$[F_1 = 32.8 \text{ kN}; \Delta L_B = 0.073 \text{ mm}; \sigma_{GB} = 12.73 \text{ MPa}; \sigma_{BC} = 10.19 \text{ MPa}]$$

Problem 2.13

Link DB in Fig. 2.53 is made of aluminum ($E = 72 \text{ GPa}$) and has a cross-sectional area of 300 mm^2 . Link CG is made of brass ($E = 105 \text{ GPa}$) and has a cross-sectional area of 240 mm^2 . Knowing that they support rigid member HBC, determine the maximum force F that can be applied vertically at point H, if the deflection of H cannot exceed 0.35 mm .

$$[F = 16.4 \text{ kN}]$$

Problem 2.14

In Fig 2.54 a vertical load F is applied at the center B of the upper section of a homogeneous conical frustum with height h , minimum radius a , and maximum radius $2a$. Young's modulus for the material is denoted by E and we can neglect the weight of the structure. determine the deflection of point B.

$$\left[\Delta L_B = -\frac{F h}{2E \pi a^2} \right]$$

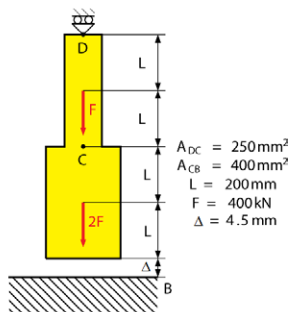


Fig. 2.55

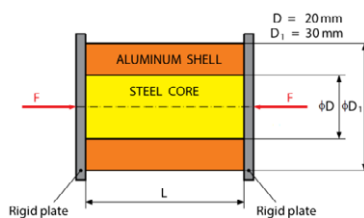


Fig. 2.56

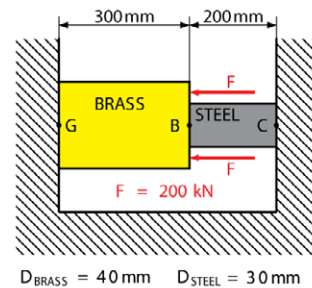


Fig. 2.57

Problem 2.15

Determine the reaction at D and B for a steel bar loaded according to Fig. 2.55, assume that a 4.50 mm clearance exists between the bar and the ground before the load is applied. The bar is steel ($E = 200 \text{ GPa}$),

$$[R_D = 430.8 \text{ kN}, R_B = 769.2 \text{ kN}]$$

Problem 2.16

Compressive centric force of $N = 1000 \text{ N}$ is applied at both ends of the assembly shown in Fig 2.56 by means of rigid end plates. Knowing that $E_{\text{STEEL}} = 200 \text{ GPa}$ and $E_{\text{ALUMINUM}} = 70 \text{ GPa}$, determine (a) normal stresses in the steel core and the aluminum shell, (b) the deflection of the assembly.

$$[\sigma_{\text{ALUMINUM}} = 3.32 \text{ MPa}; \sigma_{\text{STEEL}} = 9.55 \text{ MPa}; \Delta L = 4.74 \times 10^{-3} \text{ mm}]$$

Problem 2.17

Two cylindrical rods in Fig. 2.57, one made of steel ($E_{\text{STEEL}} = 200 \text{ GPa}$) and the other of brass ($E_{\text{BRASS}} = 105 \text{ GPa}$), are joined at B and restrained by supports at G and C. For the given load, determine (a) the reaction at G and C, (b) the deflection of point B.

$$[R_G = 134 \text{ kN}; R_C = 266 \text{ kN}; DL_B = -0.3 \text{ mm}]$$

This e-book
is made with
SetaPDF





SETASIGN

PDF components for PHP developers

www.setasign.com



Problem 2.18

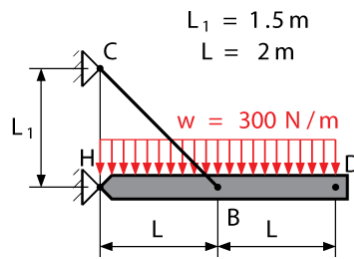


Fig. 2.58

The rigid bar HBC is supported by a pin connection at the end of rod CB which has a cross-sectional area of 20 mm^2 and is made of aluminum ($E = 68.9 \text{ GPa}$). Determine the vertical deflection of the bar at point D in Fig. 2.58 when the following distributed load $w=300\text{N/m}$ is applied.

$$[\Delta L_B = 12.1 \text{ mm}]$$

Problem 2.19



Fig. 2.59

The bar has length L and cross-sectional area A . (see Fig. 2.59) Determine its elongation due to the force F and its own weight. The material has a specific weight γ (weight / volume) and a modulus of elasticity E .

$$\left[\Delta L = \frac{\gamma L^2}{2 E} + \frac{F L}{E A} \right]$$

3 Torsion

3.1 Introduction

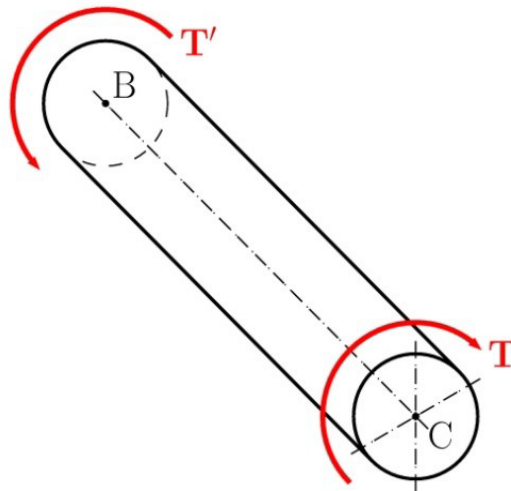


Fig. 3.1 Member in torsion



Discover the truth at www.deloitte.ca/careers

Deloitte.

© Deloitte & Touche LLP and affiliated entities.



Click on the ad to read more

In the previous chapter we discussed axially loaded members and we analyzed the stresses and strains in these members, but we only considered the internal force directed along the axis of each member without observing any other internal force. Now we are going to analyse stresses and strains in members subjected to *twisting couples* or *torques* T and T' , see Fig. 3.1. Torques have a common magnitude and opposite sense and can be represented either by curved arrows or by couple vectors, see Fig. 3.2.

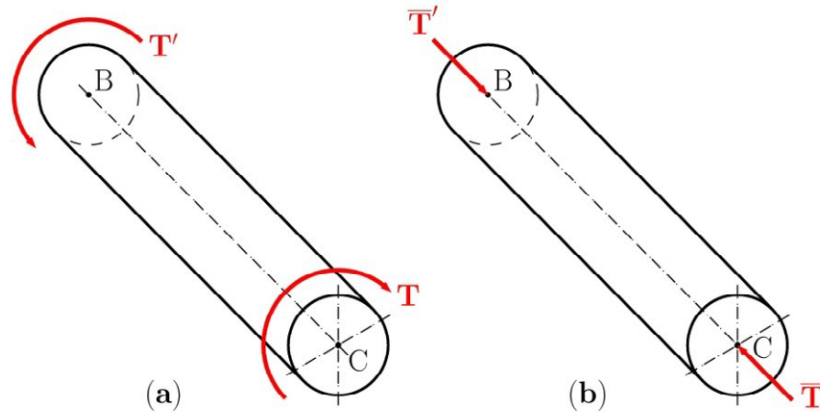


Fig. 3.2 Alternative representations of torques

Members in torsion are encountered in many engineering applications and are primarily used to transmit power from one point to another. These shafts play important roles in the automotive and power industry. Some applications are presented in Fig. 3.3.

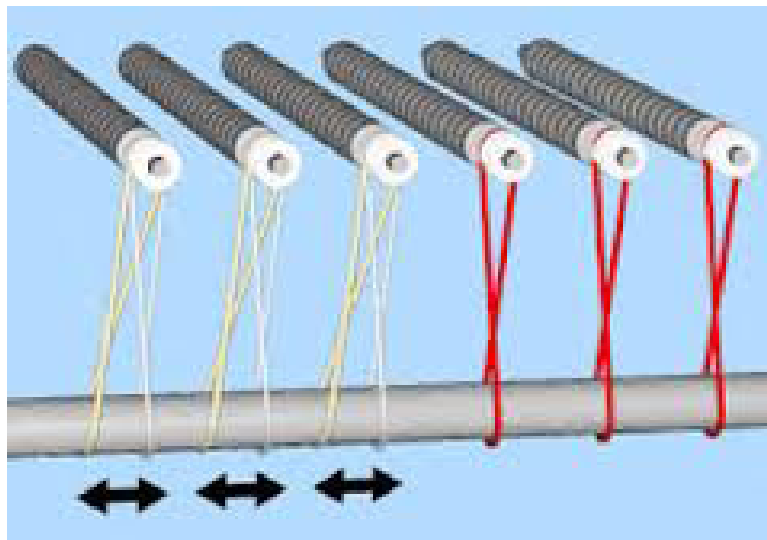


Fig. 3.3 Transmitting shafts, <http://www.directindustry.com>

There is a parallelism between an axially loaded member and a member in torsion. Both vectors of applied force \bar{F} and applied torque \bar{T} act in the direction of the member axes, see Fig. 3.4. Further on, will see the results of a deformation analysis speak more about this parallelism.

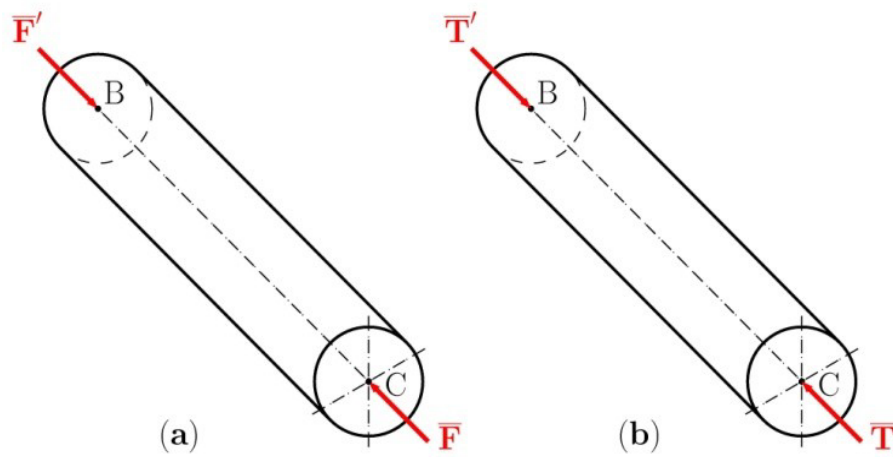


Fig. 3.4 Parallelism

This chapter contains two different approaches in solving torsion problems. Firstly we will present the theory for members with circular cross-sectional areas (circular members in short) and secondly we will extend our knowledge of this theory for application on non-circular members.

3.2 Deformation in a Circular Shaft

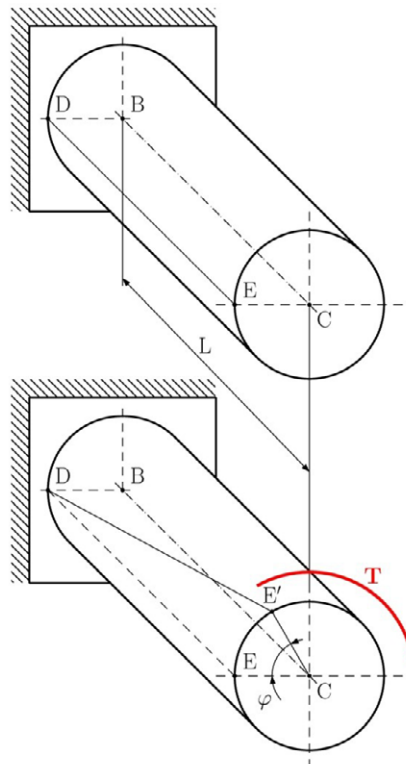


Fig. 3.5

Let us consider a circular shaft fixed to a support at point B while the other end is free, see Fig. 3.5. The shaft is of length L with constant circular cross-sectional area A . If the torque T is applied at point C (free end of shaft), then the shaft will twist, i.e. the free end will rotate about the shaft axis through *the angle of twist* φ and the shaft axis remains straight after applying the load.

Before applying the load, we can draw a square mesh over the cylindrical surface of the shaft as well as varying diameters on the front circular surface of the shaft, see Fig. 3.6(a). After applying the load and under the assumption of a small angle of twist (less than 5°) we can observe the distortion in Fig. 3.6(b):

1. All surface lines on the cylindrical part rotate through the same angle γ .
2. The frontal cross-sections remain in the original plane and the shape of every circle remains undistorted as well.
3. Diameters on the front face remain straight.
4. The distances between concentric circles remain unchanged.

© 2013 Accenture. All rights reserved.

be > your degree

Bring your talent and passion to a global organization at the forefront of business, technology and innovation. Discover how great you can be.

Visit accenture.com/bookboon

Be greater than.
consulting | technology | outsourcing

accenture
High performance. Delivered.

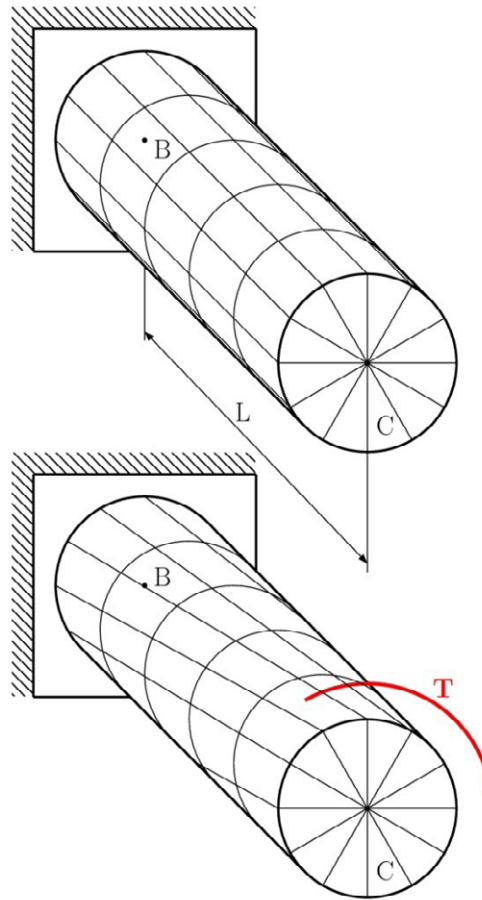


Fig. 3.6

These experimental observations allow us to conclude the following hypotheses:

1. All cross-sectional areas remain in the original plane after deformation.
2. Diameters in all cross-sections remain straight.
3. The distances between any arbitrary cross-sections remain unchanged.

The acceptability of these hypotheses is proven by experimental results. The aforementioned hypotheses result in no strain along the member axis. Applying equation (2.5) for isotropic material, we get

$$\varepsilon_x = 0 \Rightarrow \varepsilon_y = \varepsilon_z = 0 \quad (3.1)$$

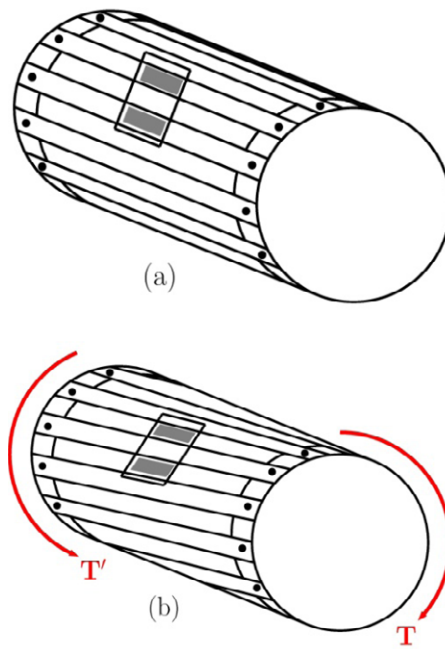
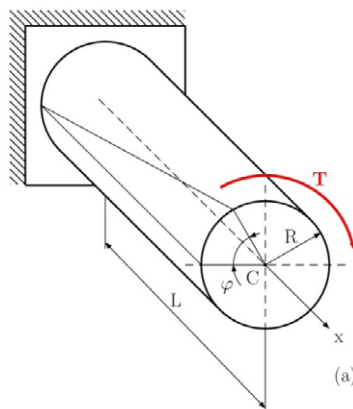


Fig. 3.7

Using equations of elasticity (2.10) we have $\sigma_x = 0$. Equation (3.1) means that the edge dimensions of the unit cube are unchanged, but the shape of unit cube is changing. This can be proven with a small experiment. Let us imagine a circular member composed of two wooden plates which represent the faces on the front of the member. Now consider several wooden slats that are nailed to these plates and make up the cylindrical surface of the member, see Fig. 3.7. Let us make two markers on each neighbouring slat, see Fig. 3.7(a). These markers represent the top surface of the unit cube. After applying a load, the markers will slide relative to each other, see Fig. 3.7(b). The square configuration will then be deformed into a rhombus which proves the existence of a shearing strain.



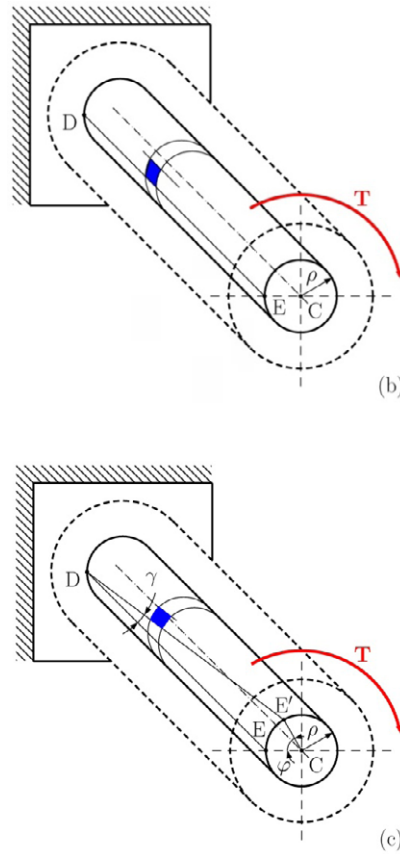
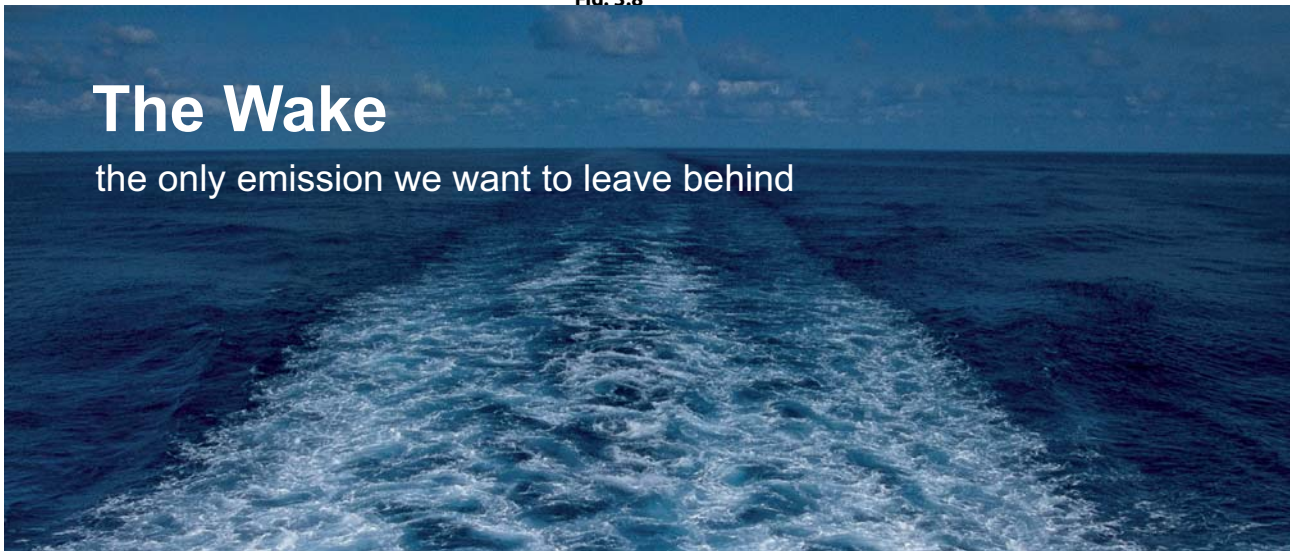


Fig. 3.8



The Wake

the only emission we want to leave behind

Low-speed Engines Medium-speed Engines Turbochargers Propellers Propulsion Packages PrimeServ

The design of eco-friendly marine power and propulsion solutions is crucial for MAN Diesel & Turbo. Power competencies are offered with the world's largest engine programme – having outputs spanning from 450 to 87,220 kW per engine. Get up front! Find out more at www.mandieselturbo.com

Engineering the Future – since 1758.
MAN Diesel & Turbo



Click on the ad to read more

We can now determine the shearing strain distribution in a circular shaft, see Fig. 3.5, and which has been twisted through the angle φ , see Fig. 3.8(a). Let us detach the inner cylinder of radius ρ , $\rho \in (0, R)$ from the shaft. Now let's consider a small square element on its surface formed by two adjacent circles and two adjacent straight lines traced on the surface of the cylinder before any load is applied, see Fig. 3.8(b). Now subjecting the shaft to the torque T , the square element becomes deformed into a rhombus, see Fig. 3.8(c). Recalling that, in section 2.5, the angular change of element represents the shearing strain. This angular change must be measured in radians.

From Fig. 3.8(c) one can determine the length of arc EE' using basic geometry: $EE' = L\gamma$ or $EE' = \rho\varphi$.

Then we can derive

$$\gamma = \frac{\rho\varphi}{L} \quad (3.2)$$

where γ , φ are both considered to be in radians. From equation (3.2) it is clear for a given point on the shaft that the shearing strain varies linearly with the distance ρ from the shaft axis.

Due to the definition of inner radius ρ the shearing strain reaches its maximum on the outer surface of the shaft, where $\rho = R$. Then we get

$$\gamma_{max} = \frac{R\varphi}{L} \quad (3.3)$$

Using equations (3.2) and (3.3) we can eliminate the angle of twist. Then we can express the shearing strain γ at an arbitrary distance from the shaft axis by the following:

$$\gamma = \frac{\rho}{R} \gamma_{max} \quad (3.4)$$

3.3 Stress in the Elastic Region

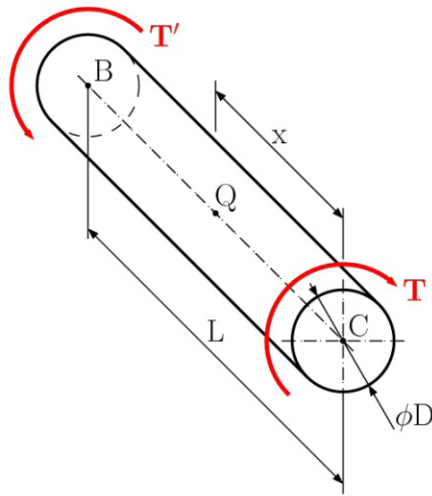


Fig. 3.9

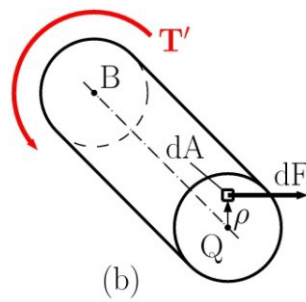
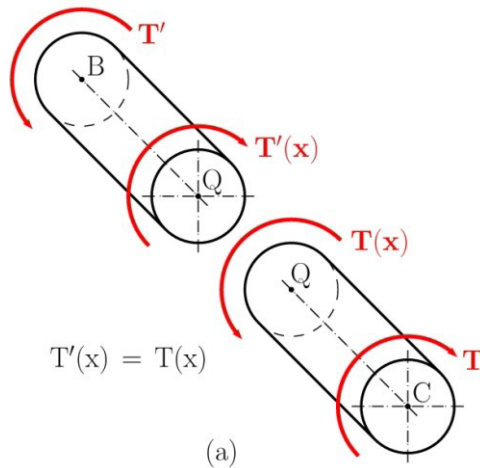


Fig. 3.10

Let us consider a section BC of the circular shaft with constant diameter D along its length L , subjected to torques T and T' at its ends, see Fig. 3.9. Applying the method of sections, we can divide the shaft into two arbitrary portions BQ and QC at any arbitrary point Q. In order to satisfy conditions of equilibrium for each part separately, we need to represent the removed part with internal forces. In our case, from the equilibrium equations, we get non-zero values only for the torque $T(x)$, see Fig. 3.10(a). This torque represents the resultant of all elementary shearing forces dF exerted on a section at point Q, see Fig. 3.10 (b). If the portion BQ is twisted, we can write

$$\int \rho dF = T_{(x)} \quad (3.5)$$

where ρ is the perpendicular distance from the force dF to the shaft axis. The shearing force dF can be expressed as follows $dF = \tau dA$, then substituting into equation (3.5) we get

$$\int \rho \tau dA = T_{(x)} \quad (3.6)$$

Recalling Hooke's law from Section 2.5 we can write

$$\tau = G\gamma \quad (3.7)$$

SMS from your computer

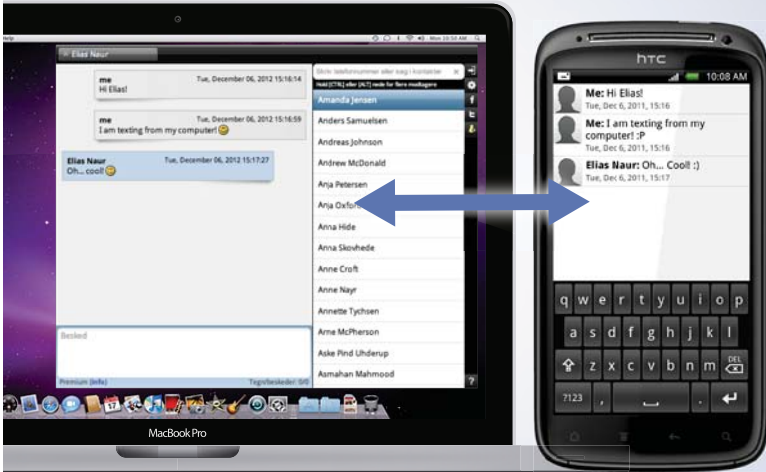
...Sync'd with your Android phone & number


FREE
30 days trial!


Go to

BrowserTexting.com

and start texting from your computer!




BrowserTexting



Click on the ad to read more

and applying equation (3.4) we get

$$G\gamma = \frac{\rho}{R} G\gamma_{max} \quad (3.8)$$

or

$$\tau = \frac{\rho}{R} \tau_{max} \quad (3.9)$$

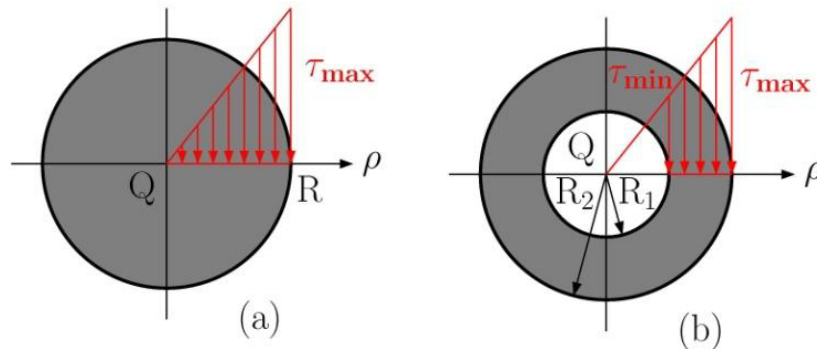


Fig. 3.11

This equation shows that the shearing stress also varies linearly with the distance ρ from the shaft axis, as long as the yield stress is not exceeded. The distribution functions of shearing stress are presented in Fig. 3.11(a), for a solid circle, and in Fig. 3.11(b) for a hollow circle ($\rho \in \langle R_1, R_2 \rangle$). For the latter case we can write

$$\tau_{min} = \frac{R_1}{R_2} \tau_{max} \quad (3.10)$$

The integral equation (3.6) determines the relationship between the resultant of internal forces $T(x)$ and the shearing stress τ . Substituting τ from equation (3.9) into (3.6) we get

$$T_{(x)} = \frac{\tau_{max}}{R} \int \rho^2 dA \quad (3.12)$$

The integral in the last member represents the polar moment of inertia J with respect to its centre O , for more detail see Appendix A. Then we have

$$T_{(x)} = \frac{\tau_{max}}{R} J \quad \text{or} \quad \tau_{max} = \frac{T_{(x)}}{J} R \quad (3.13)$$

Substituting equation (3.9) into (3.13) we get

$$\tau = \frac{T_{(x)}}{J} \rho \quad (3.14)$$

3.4 Angle of Twist in the Elastic Region

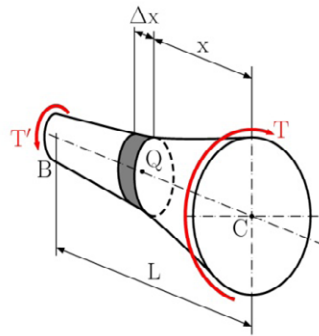


Fig. 3.12

When observing the deformation of a circular shaft subjected to a torque T , see Fig. 3.12, we can see the rotation of the free end C , about the shaft's axis or angle of twist φ . The entire shaft remains in the elastic region after applying the load. The considered shaft has a constant, circular cross-section with a maximum radius R , and a length of L . Now we can recall equation (3.3) where the maximum shearing strain γ_{max} and the angle of twist are related by the following

$$\gamma_{max} = \frac{R\varphi}{L} \quad (3.3)$$

We are assuming that there is elastic response, therefore we can apply Hooke's law for simple shear $\gamma_{max} = \tau_{max}/G$. After substituting equation (3.13) into Hooke's law, and knowing that $T(x) = T$ along the whole axis of the shaft, we get

$$\gamma_{max} = \frac{T(x)R}{GJ} = \frac{T}{GJ}R \quad (3.15)$$

Equating the right-hand members of equations (3.3) and (3.15), and solving for φ we have

$$\varphi = \frac{T(x)L}{GJ} = \frac{TL}{GJ} \quad (3.16)$$

The obtained formula shows that the angle of twist is proportional to the applied torque within the elastic region. If we compare the results of equation (2.15) from chapter 2, one can conclude the following parallelism: $\Delta L \triangleq \varphi$, $N_{(x)} \triangleq T_{(x)}$, $E \triangleq G$, $A \triangleq J$. This equation is valid only if the shaft is made of homogenous material (constant G), has a uniform cross-sectional area (constant J), and is loaded at its ends.

If the shaft is composed from several different parts, each individually satisfying the validity of equation (3.16), we can extend formula (3.16) using the principles of superposition as follows:

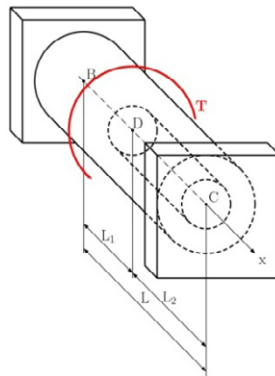
$$\varphi = \sum_{i=1}^n \varphi_i = \sum_{i=1}^n \frac{T_i(x) L_i}{G_i J_i} \quad (3.17)$$

where $T_{i(x)}$, G_i , J_i , L_i is the internal torque, shear modulus, polar moment of inertia and length corresponding to the part i respectively.

In the case of variable cross-sectional area along the shaft, as in Fig.3.12, the strain depends on the position of the arbitrary point Q, therefore we must apply a similar equation to (2.2) for the computation of the shearing strain. After some mathematical manipulation the total angle of twist of the member is

$$\varphi = \int_{(L)} \frac{T_{(x)}}{GJ} dx \quad (3.18)$$

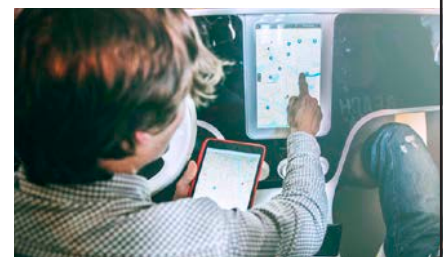
3.5 Statically indeterminate Shafts



**YOUR WORK AT TOMTOM WILL
BE TOUCHED BY MILLIONS.
AROUND THE WORLD. EVERYDAY.**

Join us now on www.TomTom.jobs

follow us on **LinkedIn**



#ACHIEVEMORE

TOMTOM 



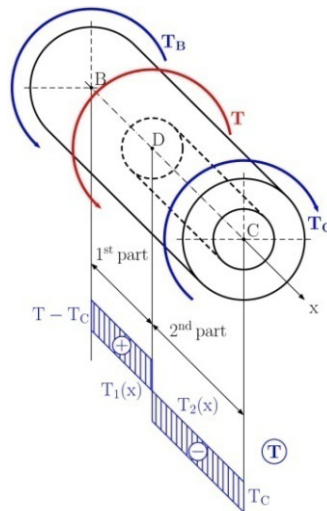


Fig. 3.13

Until now, we have discussed statically determinate problems. But there are some situations, where the internal torques can not be determined using statics alone. For simplicity, let us consider a simple problem, see Fig. 3.13. In this case we cannot solve the problem through equilibrium equations from statics alone. The main difficulty in this problem is that the number of unknown reactions is greater than the number of equilibrium equations. From a mathematical point of view, the problem is ill-conditioned. For our case we obtain one equilibrium equation to be

$$\sum T_x = 0 : T_C - T + T_B = 0 \quad (3.18)$$

This problem is statically indeterminate. To overcome this difficulty we must use the same approach as in Chapter 2, Section 2.7, i.e. to add deformation conditions. In our case the angle of twist at point C is equal to zero, and corresponds to the total angle of twist

$$\varphi = \varphi_C = \sum_{i=1}^2 \varphi_i = 0 \quad (3.19)$$

Using equation (3.17) we obtain

$$\varphi = \sum_{i=1}^2 \varphi_i = \varphi_1 + \varphi_2 = \frac{T_1(x) L_1}{G J_1} + \frac{T_2(x) L_2}{G J_2} = 0 \quad (3.20)$$

Both internal torques $T_1(x) = T - T_C$, $T_2(x) = T_C$ are functions of unknown reaction T_C . Solving equation (3.20) we obtain the value of reaction $T_C = \frac{J_2 L_1}{(J_2 L_1 - J_1 L_2)} T$. We can then continue by solving in the usual way (for statically determinate problems).

3.6 Design of Transmission Shafts

In designing transmission shafts the principal specifications that must be satisfied are the power to be transmitted and the velocity of rotation. Our task now is to select the material and the type and the size of cross-section to satisfy the strength condition, i.e. the maximum shearing stress will not exceed the allowable shearing stress $\tau_{max} \leq \tau_{All}$, when the shaft is transmitting the required power at the specified velocity. Recalling elementary physics we have

$$P = T\omega = 2\pi fT \quad (3.21)$$

Where P is the transmitted power, ω is the angular velocity, and f is the frequency of rotation. Solving equation (3.21) for T obtains the torque exerted on our shaft which is transmitting the required power P at a frequency of rotation f ,

$$T = \frac{P}{2\pi f} \quad (3.22)$$

Now we can apply the strength condition using equation (3.13) as follows

$$\tau_{max} = \frac{T}{J}R \leq \tau_{all} \quad (3.23)$$

Substituting equation (3.22) into (3.23) we get

$$\frac{P}{2\pi fJ}R \leq \tau_{all} \quad \text{or} \quad \frac{J}{R} \geq \frac{P}{2\pi f\tau_{All}} \quad (3.24)$$

The value J/R represents the allowable minimum. This variable is known as *the section modulus* and can be found in any common section standards.

3.7 Torsion of Non-Circular Members

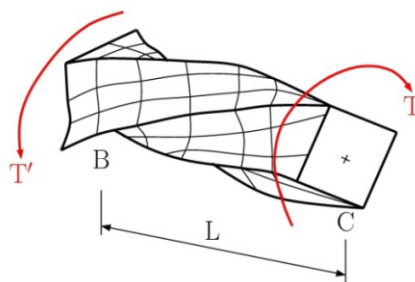


Fig. 3.14

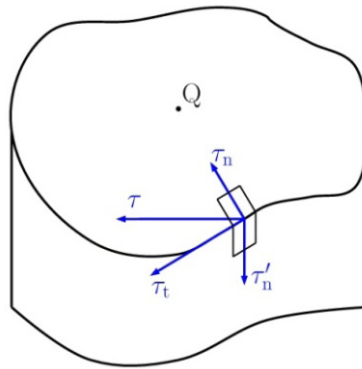


Fig. 3.15

All previous formulas have been derived upon the axisymmetry of deformed members. Let us now consider the shaft with square cross-section, see Fig. 3.14. Experimental results show that the cross-section of this type warped out of their original plane. Therefore we cannot apply relations which are otherwise valid for circular members. For example, for a circular shaft the shearing stress varies linearly along the distance from the axis. Therefore, one could expect that the maximum stresses are at the corners of the square cross-sections but they are actually equal to zero. For this reason, we can consider a torsionally loaded bar, with an arbitrary non-circular cross-section, see Fig. 3.15. The shearing stress acts in an arbitrary direction on the contour of the cross-section. This stress τ has two components: a normal component τ_n and the tangential component τ_t . Due to the shear law, component τ'_n must exist. But there is no load in that direction and therefore this stress is equal to zero and subsequently $\tau_n = \tau'_n = 0$. The result means that in the vicinity of contour, the shearing stress is in the direction of tangent to the contour.

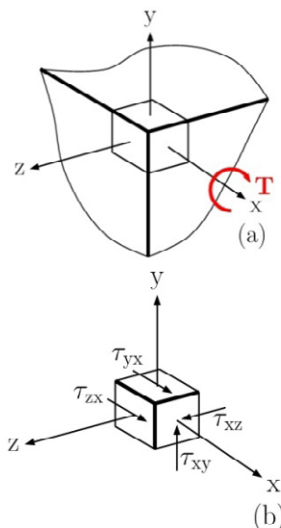


Fig. 3.16

Now let us consider a small unit cube at the corner of a square cross-section, see Fig. 3.16(a). The corner is the intersection point of two contour lines. Therefore at the corner we have two tangential components τ_{xy} and τ_{xz} , see Fig. 3.16(b). According to the shear law, other shearing components, τ_{yx} and τ_{zx} , must exist. Both are on the free surface, and there is no load in the x-axis direction. We can then write

$$\tau_{yx} = 0 \quad \text{and} \quad \tau_{zx} = 0 \tag{3.25}$$

and it follows that

$$\tau_{xy} = 0 \quad \text{and} \quad \tau_{xz} = 0 \tag{3.26}$$

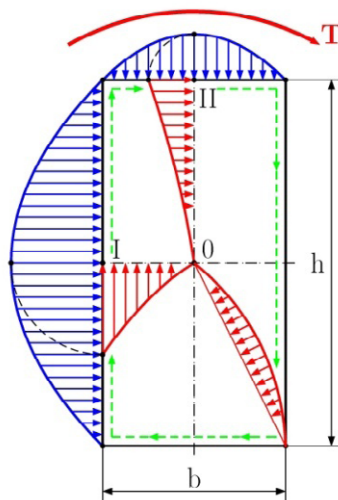


Fig. 3.17

Let us imagine a small experiment, let's twist a bar with square cross-section and made of a rubber-like material. We can verify very easily, that there are no stresses and deformations along the edges of the bar and the largest deformations and stresses are along the centrelines of the bars faces.

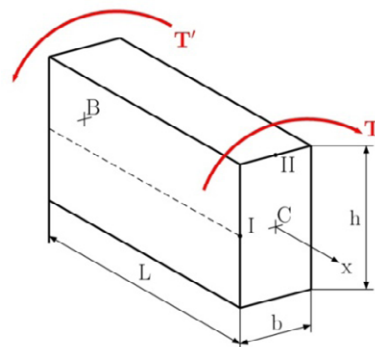


Fig. 3.18

Applying the methods of mathematical theory of elasticity for the bar with rectangular cross-section $b \times h$, we will get the stress distribution functions presented in Fig. 3.17. The corner stresses are equal to zero. We can find the two local stresses which are largest at point I and II (Roman numerals). Denoting L as the length of the bar, b and h as the narrow and wide side of bar cross-section respectively and T as the applied torque, see Fig. 3.18, we have

$$\tau_I = \tau_{max} = \frac{T}{\alpha h b^2} \quad \text{and} \quad \tau_{II} = \beta \tau_I \quad (3.27)$$

The coefficient α, β depend only upon the ratio h/b . The angle of twist can be expressed as

$$\varphi = \frac{TL}{\gamma G h b^3} \quad (3.28)$$

The coefficient γ also depends only upon the ratio h/b . All coefficients α, β, γ are presented in the following Tab. 3.1.

h/b	1,00	1,50	1,75	2,00	2,50	3,00	4,00	6,00	8,00	10,00	∞
α	0,208	0,231	0,239	0,246	0,258	0,267	0,282	0,299	0,307	0,313	0,333
β	1,000	0,859	0,820	0,795	0,776	0,753	0,745	0,743	0,742	0,742	0,742
γ	0,141	0,196	0,214	0,229	0,249	0,263	0,281	0,299	0,307	0,313	0,333

Tab. 3.1

Brain power

By 2020, wind could provide one-tenth of our planet's electricity needs. Already today, SKF's innovative know-how is crucial to running a large proportion of the world's wind turbines.

Up to 25 % of the generating costs relate to maintenance. These can be reduced dramatically thanks to our systems for on-line condition monitoring and automatic lubrication. We help make it more economical to create cleaner, cheaper energy out of thin air.

By sharing our experience, expertise, and creativity, industries can boost performance beyond expectations. Therefore we need the best employees who can meet this challenge!

The Power of Knowledge Engineering

Plug into The Power of Knowledge Engineering.
Visit us at www.skf.com/knowledge

SKF

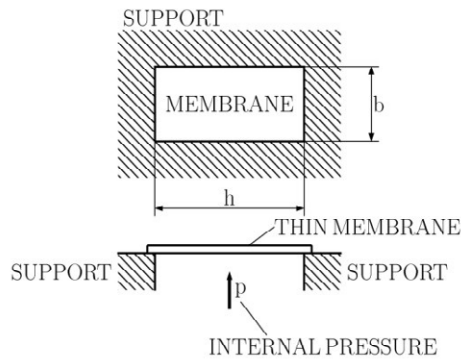


Fig. 3.19

The stress distribution function over the non-circular cross-section can be visualised by *the membrane analogy*. Firstly, what does this analogy mean? Two processes are analogous if both can be describe by the same type of equations. In our case we have the twisting of a non-circular bar and the deformation of a thin membrane subjected to internal pressures, see Fig. 3.19. Both processes are determined by the same type of differential equations. Secondly, we need to determine the analogous variables. In our case we have

$$\begin{aligned}
 T &\triangleq \text{volume bouded by the deformed membrane and horizontal plane} \\
 \text{value of shearing strain} &\triangleq \text{tangent of maximum slope} \\
 \text{direction of shearing strain} &\triangleq \text{horizontal tangent}
 \end{aligned}
 \tag{3.29}$$

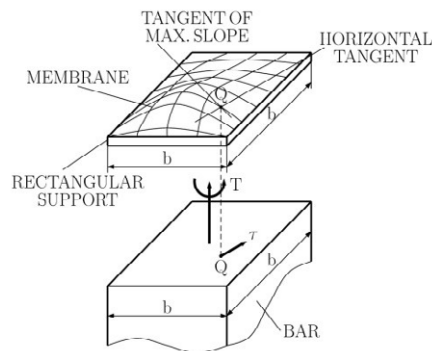


Fig. 3.20

The graphical representation of these equations is presented in Fig. 3.20.

The membrane analogy can be efficiently applied for members whose cross-section can be unrolled into the basic rectangle $b \times h$, see Fig. 3.21. Another application of the membrane analogy is for members with cross-sections composed from several rectangles, see Fig. 3.22. These cross-sections cannot be unrolled into one simple rectangle $b \times h$. For this case we can assume that the total volume of deformed membrane is equal to the sum of individually deformed membranes, see Fig. 3.23. If the torque is analogous to the membrane volume, and then we can write

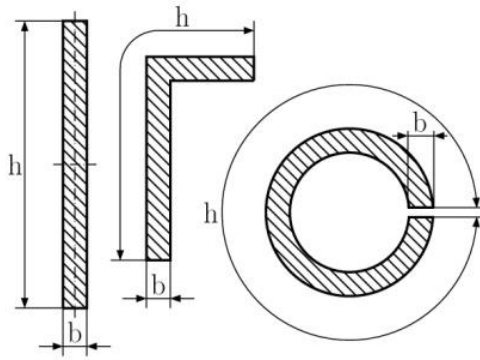


Fig. 3.21

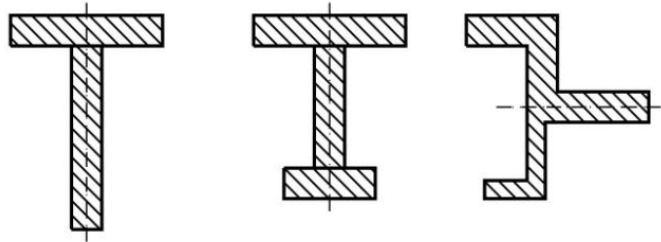


Fig. 3.22

$$T \doteq T_1 + T_2 + \dots + T_n \tag{3.30}$$

$$\varphi = \varphi_1 = \varphi_2 = \dots = \varphi_n$$

After simple mathematical manipulations of these equations we determine that the total torsional stiffness is equals to the sum of individual torsional stiffness' of each rectangle, i.e.

$$\gamma hb^3 = \sum_{i=1}^n \gamma_i h_i b_i^3 \tag{3.31}$$

subsequently the largest stress corresponding to each rectangle can be found by

$$\tau_i = \frac{T_i}{\alpha_i h_i b_i^2} \tag{3.33}$$

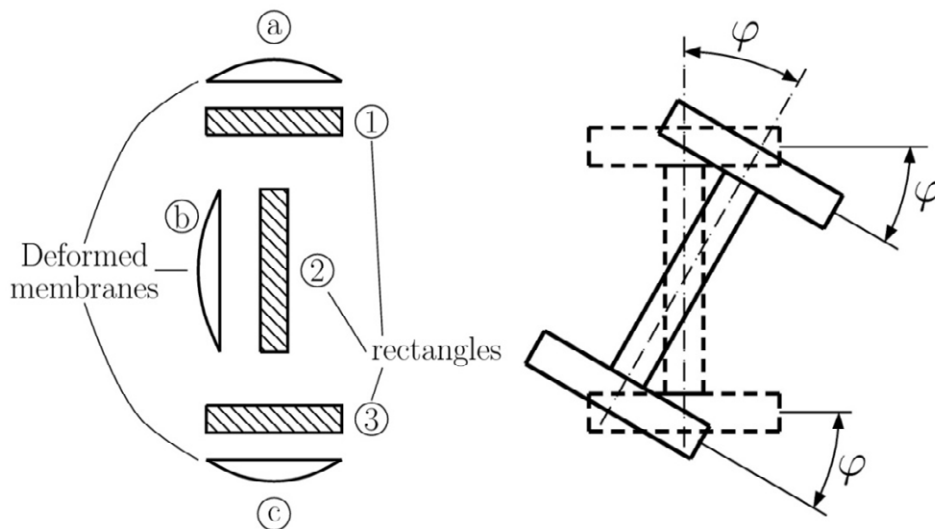


Fig. 3.23

3.8 Thin-Walled hollow Members

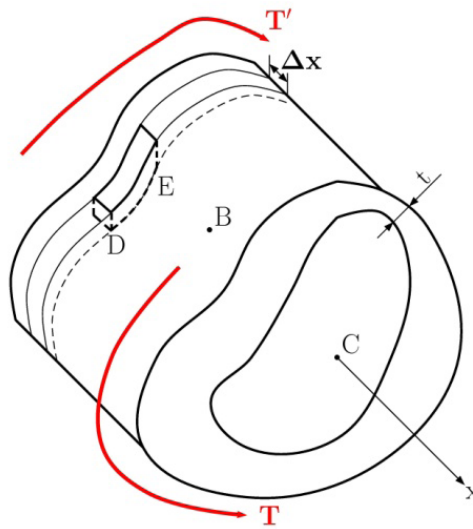


Fig. 3.24

In the previous section we discussed members with open non-circular cross-sections subjected to torsional loading. The results obtained in the previous section required advanced theory of elasticity. For thin-walled hollow members we can apply some simple computations to obtain results.

> Apply now

REDEFINE YOUR FUTURE
**AXA GLOBAL GRADUATE
 PROGRAM 2015**

redefining / standards 

agence.cdg © Photonistop

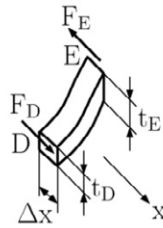


Fig. 3.25

Let us consider the thin-walled hollow member of non-circular cross-section, see Fig. 3.24. The wall thickness varies within the transverse section and remains very small in comparison to other dimensions. Let us detach a small coloured portion DE. This portion is bounded by two parallel transverse sections by the distance Δx and two parallel longitudinal planes. Focusing on the equilibrium of part DE in the longitudinal direction x , the shear law says that the shear forces F_D , F_E are exerted on faces D and E, see Fig. 3.25. We then get the corresponding equation

$$\sum F_x = 0 : F_D - F_E = 0 \quad (3.34)$$

The longitudinal shear forces F_D , F_E are acting on the small faces of areas $\Delta x t_D$ and $\Delta x t_E$. Thus we can express the force as a product of shearing stress and area, i.e.

$$F_D = \tau_D A_D = \tau_D \Delta x t_D, \quad F_E = \tau_E A_E = \tau_E \Delta x t_E \quad (3.35)$$

Substituting equation (3.35) into (3.34) we get

$$\tau_D \Delta x t_D - \tau_E \Delta x t_E = 0$$

or (3.36)

$$\tau_D t_D = \tau_E t_E$$

Since the selection of portion DE is arbitrary, and then the product τt is constant throughout the member. Denoting this product by q we get

$$q = \tau t = \text{constant} \quad (3.37)$$

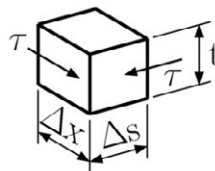


Fig. 3.26

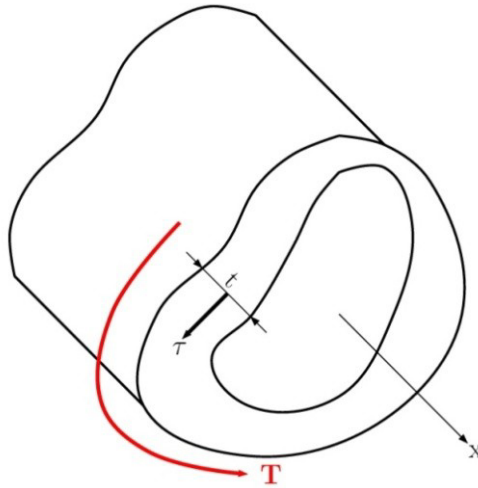


Fig. 3.27

This new variable describes the shear flow in the member. The direction of shearing stress is determined by the direction of shear forces and the application of the shear law as one can see in Fig. 3.26 and Fig. 3.27.

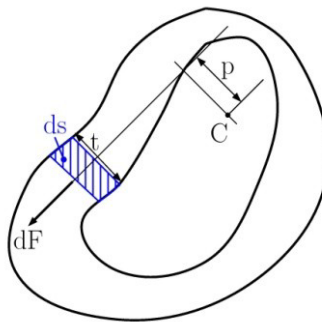


Fig. 3.28

Now let us consider a small element ds which is a portion of the wall section, see Fig. 3.28. The corresponding area is $dA = tds$. The resultant of shearing stresses exerted within this area is denoting by dF or

$$dF = \tau dA = \tau t ds = q ds \quad (3.38)$$

The moment dM_C of this force about the arbitrary point C is

$$dM_C = p dF = p q ds = q p ds \quad (3.39)$$

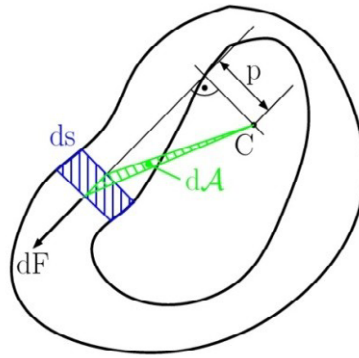


Fig. 3.29

Where p is the distance of C to the action line of dF . The action line passes through the centre of this element and the product pds represents the doubled area dA , see Fig. 3.29. We then have

$$dM_C = q2dA \quad (3.40)$$

In a mathematical point of view, the integral of moments around the wall section represents the resulting moment that is in equilibrium with the applied torque T . Thus we have

$$T = \oint dM_C = \oint q2dA \quad (3.41)$$

LIGS University

based in Hawaii, USA

is currently enrolling in the
Interactive Online **BBA, MBA, MSc,**
DBA and PhD programs:

- ▶ enroll **by October 31st, 2014** and
- ▶ **save up to 11%** on the tuition!
- ▶ pay in 10 installments / 2 years
- ▶ Interactive **Online** education
- ▶ visit www.ligsuniversity.com to find out more!

Note: LIGS University is not accredited by any nationally recognized accrediting agency listed by the US Secretary of Education. More info [here](http://www.ligsuniversity.com).





Since the shear flow is constant, we get

$$T = q \oint 2d\mathcal{A} = q2\mathcal{A} \tag{3.42}$$

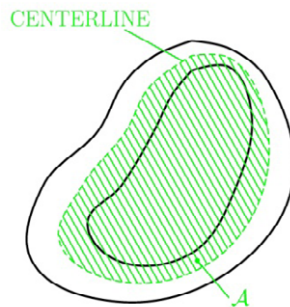


Fig. 3.30

Where \mathcal{A} is the area bounded by the centreline of the section, see Fig. 3.30. From the previous equation we can easily derive the formula for calculating the shearing stress

$$\tau = \frac{T}{2t\mathcal{A}} \tag{3.43}$$

The corresponding angle of twist can be derived by using the method of strain energy, see Appendix A.4.2. We then get

$$\varphi = \frac{TL}{4\mathcal{A}^2G} \oint \frac{ds}{t} \tag{3.44}$$

If the section can be built from several parts of constant thicknesses it is known to be piecewise constant, equation (3.44) can then be simplified

$$\varphi = \frac{TL}{4\mathcal{A}^2G} \sum_{i=1}^n \frac{\Delta s_i}{t_i} \tag{3.45}$$

3.9 Examples, Solved and Unsolved Problems

Problem 3.1

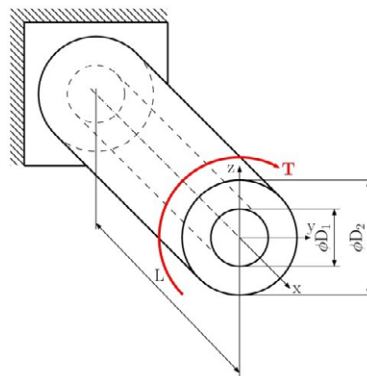


Fig. 3.31

For the steel shaft with applied torque $T = 2400 \text{ Nm}$ shown in Fig. 3.31 ($G = 77 \text{ GPa}$), determine (a) the maximum and minimum shearing stress in the shaft, (b) the angle of twist at the free end. The shaft has the following dimensions: $L = 500 \text{ mm}$, $D_1 = 40 \text{ mm}$, $D_2 = 50 \text{ mm}$.

Solution

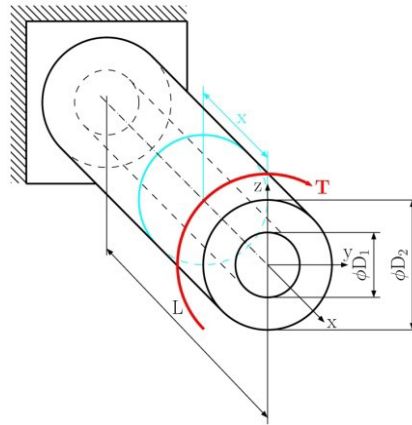


Fig. 3.32

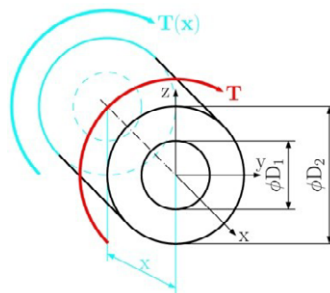


Fig. 3.32

The shaft in Fig. 3.32 consists of one portion, which has uniform cross-section area and constant internal torque. From the free body diagram in Fig. 3.33 we find that:

$$\sum M_{ix} = 0: T(x) + T = 0$$

$$T(x) = -T = -2400 \text{ Nm}$$

The polar moment of inertia (see Appendix A.2) is

$$J = J_{\text{FULL}} - J_{\text{HOLE}} = \frac{\pi D_{\text{FULL}}^4}{32} - \frac{\pi D_{\text{HOLE}}^4}{32}$$

$$J = \frac{\pi (50 \text{ mm})^4}{32} - \frac{\pi (40 \text{ mm})^4}{32} = 362265 \text{ mm}^4$$

Maximum shearing stress. On the outer surface, we have

$$\tau_{\max} = \frac{T}{J} \rho_{\max} = \frac{T D_{\text{FULL}}}{J 2} = \frac{2400 \times 10^3 \text{ N}\cdot\text{mm}}{362265 \text{ mm}^4} \times \frac{50 \text{ mm}}{2}$$

$$\tau_{\max} = 165.5 \text{ MPa.}$$

Minimum shearing stress. The stress is proportional to its distance from the axis of the shaft

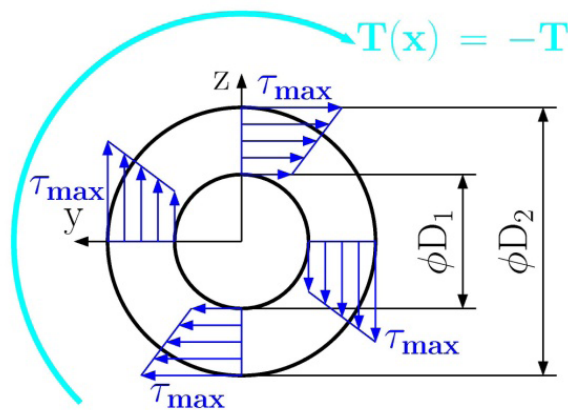


Fig. 3.34

TURN TO THE EXPERTS FOR SUBSCRIPTION CONSULTANCY

Subscribe is one of the leading companies in Europe when it comes to innovation and business development within subscription businesses.

We innovate new subscription business models or improve existing ones. We do business reviews of existing subscription businesses and we develop acquisition and retention strategies.

Learn more at [linkedin.com/company/subscribe](https://www.linkedin.com/company/subscribe) or contact Managing Director Morten Suhr Hansen at mha@subscribe.dk

SUBSCR✓**IBE** - to the future

$$\frac{\tau_{\min}}{\tau_{\max}} = \frac{\frac{D_1}{2}}{\frac{D_2}{2}} = \frac{D_1}{D_2} \Rightarrow \tau_{\min} = \tau_{\max} \frac{D_1}{D_2}$$

$$\tau_{\min} = 165.6 \text{ MPa} \frac{40 \text{ mm}}{50 \text{ mm}} = 132.5 \text{ MPa}$$

Another way to determine this is by:

$$\tau_{\min} = \frac{T}{J} \rho_{\min} = \frac{T}{J} \frac{D_{\text{HOLE}}}{2} = \frac{2400 \times 10^3 \text{ N}\cdot\text{mm}}{362265 \text{ mm}^4} \times \frac{40 \text{ mm}}{2}$$

$$\tau_{\min} = 132.5 \text{ MPa}.$$

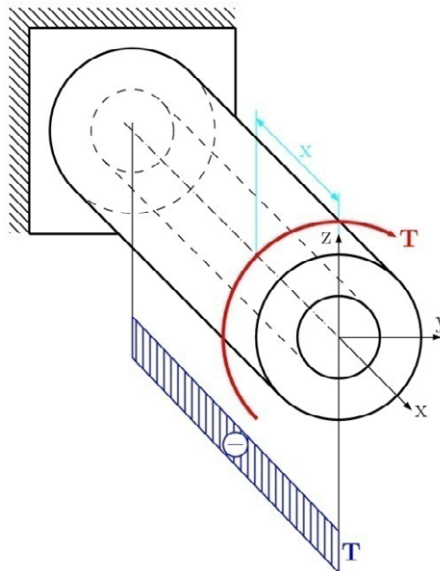


Fig. 3.35

Graphically we can show shearing stress in Fig. 3.34 and the diagram of torque along the length of the shaft is shown in Fig. 3.35.

Angle of twist.

Using Eq. (3.16) and recalling that $G = 77 \text{ GPa}$ for the shaft we obtain

$$\varphi = \frac{T L}{G J} = \frac{2400 \times 10^3 \text{ N}\cdot\text{mm} \times 500 \text{ mm}}{77 \times 10^3 \text{ N}/\text{mm}^2 \times 362265 \text{ mm}^4}$$

$$\varphi = 0.043 \text{ rad} = 2.465^\circ$$

Problem 3.2

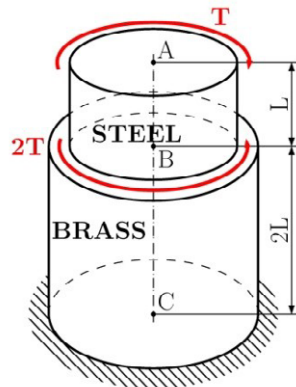


Fig. 3.36

The vertical shaft AC is attached to a fixed base at C and subjected to a torque T shown in Fig. 3.36. Determine the maximum shearing stress for each portion of the shaft and the angle of twist at A. Portion AB is made of steel for which $G = 77 \text{ GPa}$ with a diameter of $D_{\text{STEEL}} = 30 \text{ mm}$. Portion BC is made of brass for which $G = 37 \text{ GPa}$ with a diameter of $D_{\text{BRASS}} = 50 \text{ mm}$. Parameter L is equal to 100 mm

Solution

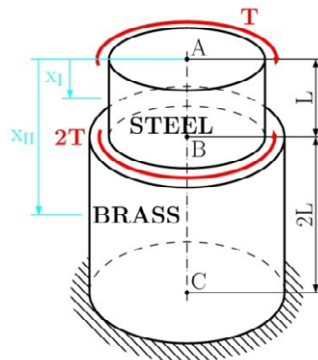


Fig. 3.37

The complete shaft consists of two portions, AB and BC (see Fig. 3.37), each with uniform cross-section and constant internal torque.

$$x_I \in \langle 0, L \rangle$$

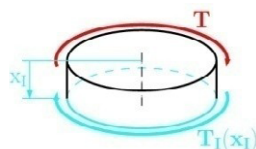


Fig. 3.38

Solution of portion AB

Passing a section through the shaft between A and B and using the free body diagram shown Fig. 3.38, we find

$$\sum M_{ixl} = 0: T_I(x) + T = 0 \quad T_I(x) = -T$$

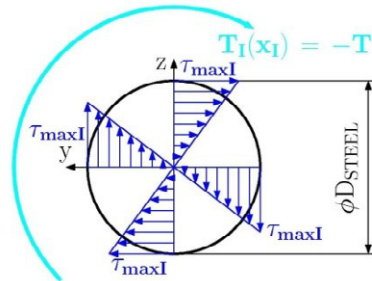


Fig. 3.38

The maximum shearing stress is on the outer surface, we have

$$\tau_{\max I} = \frac{|T|}{J} \rho_{\max I} = \frac{|T|}{J} \frac{D_{\text{STEEL}}}{2} = \frac{|T|}{\frac{\pi D_{\text{STEEL}}^4}{32}} \frac{D_{\text{STEEL}}}{2}$$

$$\tau_{\max I} = \frac{16 T}{\pi D_{\text{STEEL}}^3} = \frac{16 T}{\pi (30 \text{ mm})^3} = 1.886 \times 10^{-4} T$$

“I studied English for 16 years but...
...I finally learned to speak it in just six lessons”
Jane, Chinese architect

ENGLISH OUT THERE

Click to hear me talking before and after my unique course download

Diagram of the shearing stress across the cross-section area is shown in Fig. 3.39.

Solution of portion BC

$$x_{II} \in \langle L, 2L \rangle$$

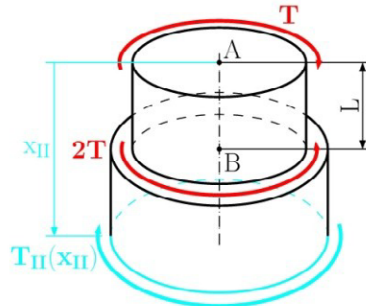


Fig. 3.40

Now passing a section between B and C (see Fig. 3.40) we obtain

$$\sum M_{ix_{II}} = 0: T_{II}(x) + T - 2T = 0 \quad T_{II}(x) = T$$

Again, the maximum shearing stress is on the outer surface, found by the following

$$\tau_{\max II} = \frac{|T_{II}|}{J} \rho_{\max II} = \frac{|T|}{J} \frac{D_{II}}{2} = \frac{|T|}{\frac{\pi D_{BRASS}^4}{32}} \frac{D_{BRASS}}{2}$$

$$\tau_{\max II} = \frac{16 T}{\pi D_{BRASS}^3} = \frac{16 T}{\pi (50 \text{ mm})^3} = 4.074 \times 10^{-5} T$$

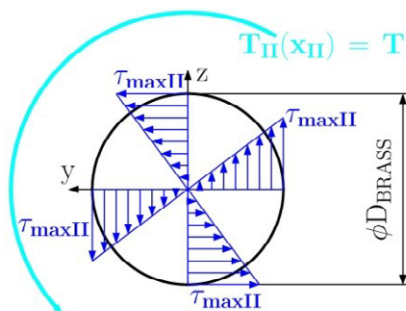


Fig. 3.41

Graphically, the shearing stress is shown in Fig. 3.41.

When we compare the results from both portions the maximum shearing stress is in portion AB, which compares with the allowable stress. From this inequality, we have the unknown torque T.

$$\tau_{\max} = \tau_{\max I} \leq \tau_{\text{All}}$$

$$\tau_{\max I} = \frac{16 T}{\pi D_{\text{STEEL}}^3} \leq \tau_{\text{All}} \Rightarrow T \leq \frac{\tau_{\text{All}} \pi D_{\text{STEEL}}^3}{16}$$

$$T \leq \frac{\tau_{\text{All}} \pi D_{\text{STEEL}}^3}{16} = \frac{150 \text{ MPa} \times \pi \times (30 \text{ mm})^3}{16} = 795215,6 \text{ Nmm}$$

$$T \leq 795215,6 \text{ Nm}$$

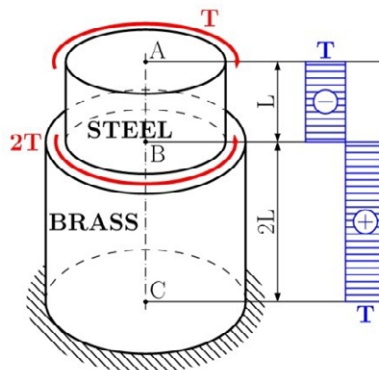


Fig. 3.42

Choosing the torque $T = 795 \text{ kNm}$. We can graphically represent the torque along the length of shaft in Fig. 3.42.

Angle of twist

Using Eq. (3.17), we have

$$\varphi = \sum_i \frac{T_i L_i}{J_i G_i}$$

$$\varphi_A = \frac{T_{AB} L_{AB}}{J_{AB} G_{AB}} + \frac{T_{BC} L_{BC}}{J_{BC} G_{BC}}$$

$$\varphi_A = \frac{T_{AB} L_{AB}}{\frac{\pi D_{\text{STEEL}}^4}{32} G_{AB}} + \frac{T_{BC} L_{BC}}{\frac{\pi D_{\text{BRASS}}^4}{32} G_{BC}}$$

$$\varphi_A = \frac{32 T_{AB} L_{AB}}{\pi D_{\text{STEEL}}^4 G_{AB}} + \frac{32 T_{BC} L_{BC}}{\pi D_{\text{BRASS}}^4 G_{BC}} = -9.48 \text{ rad}$$

Problem 3.3

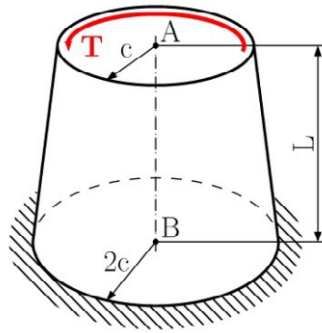


Fig 3.43

A torque T is applied as shown in Fig. 3.43 to a solid tapered shaft AB . Determine the maximum shearing stress and show, by integration, that the angle of twist at A is

$$\varphi_A = \frac{7 T L}{12 \pi G c^4}.$$

The radius c , length L , modulus of rigidity G and applied torque T , are given.

wethrive.net

How to retain your top staff
FIND OUT NOW FOR FREE

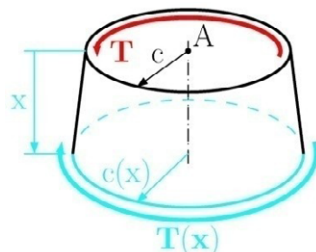
DO YOU WANT TO KNOW:

- What your staff really want?
- The top issues troubling them?
- How to make staff assessments work for you & them, painlessly?

Get your free trial
Because happy staff get more done

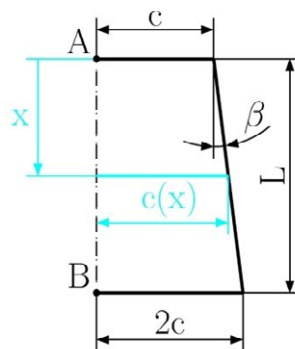
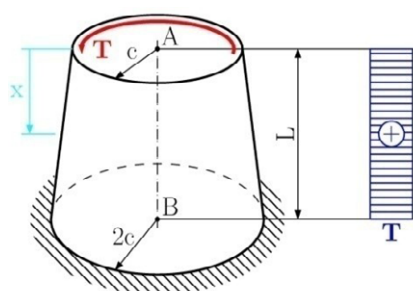
Solution

$$x_1 \in \langle 0, L \rangle$$

**Fig 3.44**

We only have one part so from free body diagram (see Fig. 3.44), we find

$$\sum M_{ix} = 0: \quad T(x) - T = 0 \quad \Rightarrow \quad T(x) = T$$

**Fig 3.45****Fig 3.46**

The maximum of shearing is on the outer surface. The radius $c(x)$ at location x is found from similarity of triangles, Fig. 3.45.

$$\tan \beta = \frac{c}{L} = \frac{c(x) - c}{x} \quad \Rightarrow \quad c(x) = c \left(1 + \frac{x}{L} \right),$$

The diameter $D(x)$ at location x is

$$D(x) = 2 c(x) \quad \Rightarrow \quad D(x) = 2 c \left(1 + \frac{x}{L} \right).$$

Moment of inertia at location x is

$$J(x) = \frac{\pi D(x)^4}{32} = \frac{\pi \left[2c \left(1 + \frac{x}{L} \right) \right]^4}{32}.$$

The maximum shearing stress at position x on the outer surface is

$$\tau_{\max}(x) = \frac{|T|}{J(x)} \rho_{\max} = \frac{|T|}{J(x)} \frac{D(x)}{2} = \frac{16 T}{\pi \left[2c \left(1 + \frac{x}{L} \right) \right]^3}$$

Angle of twist is determined from the definition of the angle of twist Eq. (3.18), and we have

$$\varphi = \int_0^L \frac{T(x)}{G J(x)} dx = \int_0^L \frac{32 T}{G \pi \left[2c \left(1 + \frac{x}{L} \right) \right]^4} dx = \frac{32 T}{G \pi 16 c^4} \int_0^L \frac{1}{\left(1 + \frac{x}{L} \right)} dx = \frac{7}{12} \frac{T L}{G \pi c^4}.$$

In the fig. 3.46 is a graph of the torque along length L .

Problem 3.4

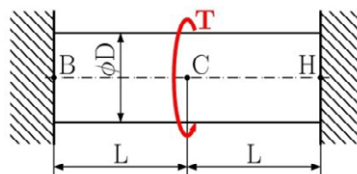


Fig. 3.47

A circular shaft BH is attached to fixed supports at both ends with a torque T applied at the midsection (Fig. 3.47). Determine the torque exerted on the shaft by each of the supports and determine the maximum shearing stress.

The length L , modulus of rigidity G and applied torque T , are given.

Solution

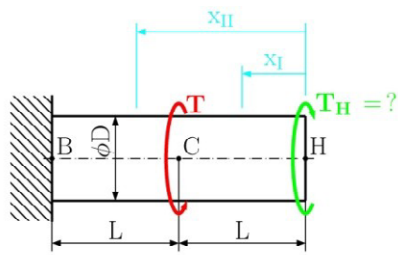
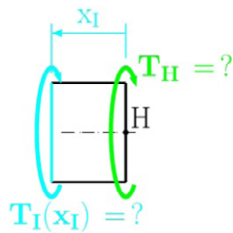


Fig. 3.48

The problem is statically indeterminate. The support at point H is replaced by an unknown support reaction T_H (horizontal and vertical reactions are equal to zero, because this is a problem of pure torsion). The solution is divided into two part (see Fig. 3.48).

Free-body diagram on portion I (part HC):

$$x_1 \in \langle 0, L \rangle$$



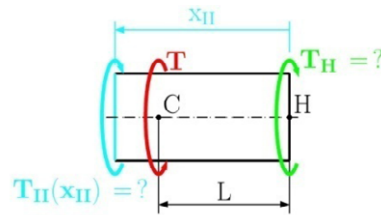
Click on the ad to read more

From the equilibrium equation of the first part, we obtain

$$\sum M_{ix_1} = 0: \quad T_1(x_1) + T_H = 0 \quad \Rightarrow \quad T_1(x_1) = -T_H$$

Free-body diagram portion II (part CB):

$$x_{II} \in \langle L, 2L \rangle$$



From the equilibrium equation of the second part, we obtain

$$\sum M_{ix_{II}} = 0: \quad T_{II}(x_{II}) - T + T_H = 0 \quad \Rightarrow \quad T_{II}(x_{II}) = -T_H - T$$

The unknown reaction is determined from the deformation condition, that the total angle of twist of shaft BH must be zero, since both of its ends are restrained. j_1 and j_2 denote the angle of twist for portions AC and CB respectively, we write

$$\varphi_H = 0 \quad \Rightarrow \quad \varphi_H = \varphi_1 + \varphi_{II} = 0 \quad \Rightarrow \quad \varphi_1 + \varphi_{II} = 0,$$

from which we have

$$\frac{T_1 L_1}{G_1 J_1} + \frac{T_{II} L_{II}}{G_{II} J_{II}} = 0,$$

where $G_1 = G_{II} = G$, $J_1 = J_{II} = J$ and $L_1 = L_{II} = L$ because both parts of shaft are made from same material, have the same cross-section area, and the same length. Then solving for T_H , we have

$$T_1(x_1) + T_{II}(x_{II}) = 0 \quad \Rightarrow \quad -T_H - T_H + T = 0 \quad \Rightarrow \quad T_H = \frac{T}{2}$$

Substituting the results for each part, we obtain

$$T_I(x_I) = -T_H = \frac{T}{2} \quad T_{II}(x_{II}) = -T_H - T = -\frac{T}{2} - T = -\frac{T}{2}$$

The diagram of torque is shown in Fig. 3.49.

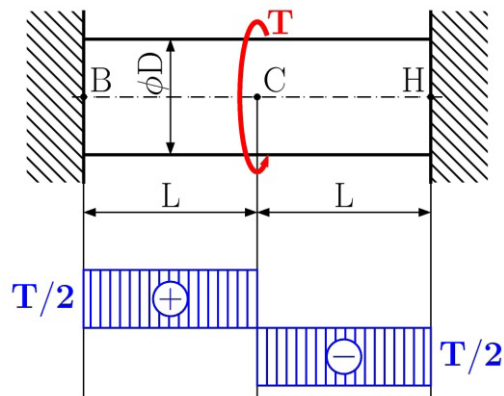


Fig. 3.49

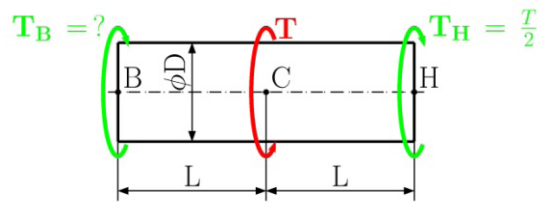


Fig. 3.50

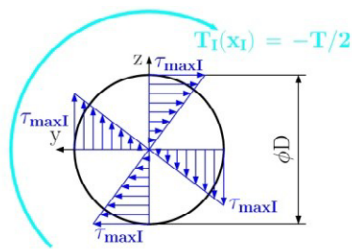


Fig. 3.51

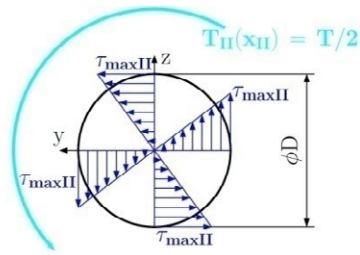


Fig. 3.52

Reaction at point B.

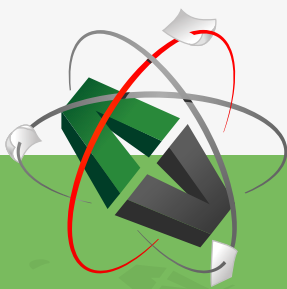
Drawing a free-body diagram of the shaft and denoting the torques exerted by supports T_B and T_H , (see Fig. 3.50) we obtain the equilibrium equation

$$\sum M_{ix_i} = 0: \quad T_B + T_H - T = 0 \quad \Rightarrow \quad T_B = T - T_H = \frac{T}{2}$$

The maximum shearing stress at part HC (outer surface) is

$$\tau_{1\max} = \frac{|T_I|}{J_I} \rho_{\max I} = \frac{\left| \frac{T}{2} \right| D}{\frac{\pi D^4}{32} \cdot 2} = \frac{16 T}{2 \pi D^3} = \frac{8 T}{\pi D^3}$$

This e-book
is made with
SetaPDF



PDF components for PHP developers

www.setasign.com



The maximum shearing stress at part BC (outer surface) is

$$\tau_{II \max} = \frac{|T_{II}|}{J_{II}} \rho_{\max II} = \frac{\frac{T}{2} \frac{D}{2}}{\frac{\pi D^4}{32}} = \frac{8 T}{\pi D^3}$$

The diagram of shearing stresses for each part is shown in the Fig. 3.51 and Fig. 3.52.

Problem 3.5

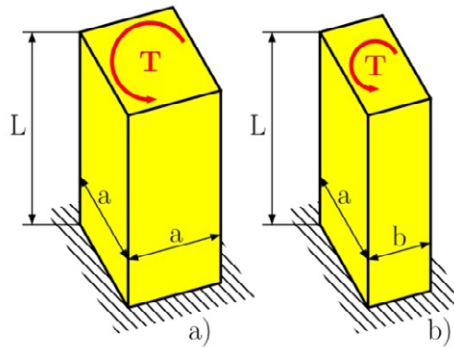


Fig. 3.53

The bars in Fig. 3.53 have a square and rectangular cross-section area. Knowing that the magnitude of torque T is 800 Nm determine the maximum shearing stress for each bar.

The dimensions are given by $L = 400$ mm, $a = 50$ mm and $b = 35$ mm

Solution

For a bar with square cross-section area (see Fig. 3.53a) and bar with rectangular cross-section area (see Fig. 3.53b), the maximum shearing stress is defined by Eq. (3.27)

$$\tau_{\max} = \frac{T}{\alpha a b^2},$$

where the coefficient α is obtained from tab. 3.1 in section 3.7. We have

$$\frac{a}{b} = \frac{50 \text{ mm}}{50 \text{ mm}} = 1 \Rightarrow \alpha = 0.208 \text{ for square cross section}$$

and

$$\frac{a}{b} = \frac{50 \text{ mm}}{30 \text{ mm}} = 1.43 \Rightarrow \alpha = 0.231 \text{ for rectangular cross section.}$$

Maximum shearing stress for square cross-section in Fig. 3.53a is

$$\tau_{\max} = \frac{T}{\alpha a b^2} = \frac{800 \text{ Nm}}{0.208 \times 0.050 \text{ m} \times (0.050 \text{ m})^2} = 30.77 \text{ MPa.}$$

Maximum shearing stress for rectangular cross-section in Fig. 3.53b is

$$\tau_{\max} = \frac{T}{\alpha a b^2} = \frac{800 \text{ Nm}}{0.208 \times 0.050 \text{ m} \times (0.035 \text{ m})^2} = 1.98 \text{ MPa.}$$

Problem 3.6

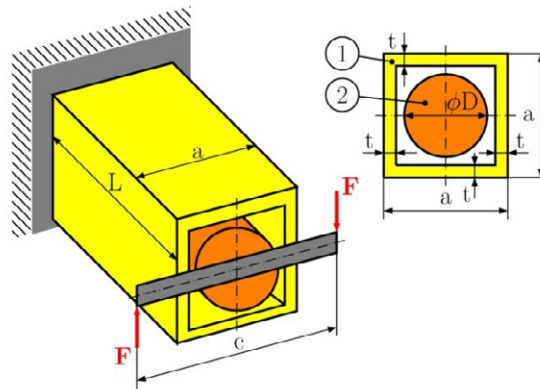


Fig. 3.54

Two shafts of the same length and made by the same materials is connected by a welded rigid beam. On the ends of the rigid beam a moment couple given by force F is applied. Cross-section area of the shaft is in Fig. 3.54. Design parameter D if we are given an allowable stress of $\sigma_{\text{all}} = 150 \text{ MPa}$.

Given: $F = 1000 \text{ N}$, $c = 200 \text{ mm}$, $a = 2D$, $t = 0.1D$, $L = 400 \text{ mm}$.

Solution

From the given force, we find the total magnitude of the torque T applied to both shafts

$$T = F c = 1000 \text{ N} \times 0.2 \text{ m} = 200 \text{ Nm}$$

This torque will then be divided on both shafts and from the equilibrium of the rigid beam, we have

$$T = T_1 + T_2 \tag{a}$$

We have two unknowns torques T_1 and T_2 , so we need a second equation, which is found from the deformation condition

$$\phi_1 = \phi_2 \quad \Rightarrow \quad \frac{T_1 L}{G J_1} = \frac{T_2 L}{G J_2}, \tag{b}$$

where angle of twist for the first cross-section area is

$$J_1 = \frac{4A^2}{\int_s \frac{ds}{t}} = \frac{4(1.9D \times 1.9D)^2}{2\left(\frac{1.9D}{0.1D} + \frac{1.9D}{0.1D}\right)} = \frac{52.1284D^4}{76} = 0.686D^4 \quad (c)$$

and for the second cross-section is

$$J_2 = \frac{\pi D^4}{32} \quad (d)$$

inserting (c) and (d) into (b), we get

$$T_1 = 6.998 T_2 \quad (f)$$

Solving the system of equations (a) and (f), we give

$$T_1 = 0.875T = 0.875 F c = 0.875 \times 200\text{Nm} = 175 \text{ Nm}$$

$$T_2 = 0.125T = 0.125 F c = 0.125 \times 200\text{Nm} = 25 \text{ Nm}$$



Discover the truth at www.deloitte.ca/careers

Deloitte.

© Deloitte & Touche LLP and affiliated entities.



Maximum shearing stress in the first cross-section is

$$\tau_{\max I} = \frac{T_1}{2 A t_{\min}} = \frac{0.875 F c}{2 \times (1.9D)^2 0.1D} = \frac{175 \text{ Nm}}{0.722 D^3} = \frac{242.4}{D^3} \text{ Nm}$$

Maximum shearing stress in the second cross-section is

$$\tau_{\max II} = \frac{T_2}{\frac{\pi D^3}{16}} = \frac{16 T_2}{\pi D^3} = \frac{16 \times 25 \text{ Nm}}{\pi D^3} = \frac{127.3}{D^3} \text{ Nm}$$

To design parameter D, we get the maximum shearing stress (from all parts), which compare with the allowable stress, we then get

$$\tau_{\max I} = \frac{242.4}{D^3} \text{ Nm} \leq \tau_{\text{All}} \Rightarrow D \geq \sqrt[3]{\frac{242.4 \text{ Nm}}{\tau_{\text{All}}}} = \sqrt[3]{\frac{242.4 \text{ Nm}}{150 \times 10^6 \text{ Nm}^2}}$$

$$D \geq 0.012 \text{ m}$$

Problem 3.7

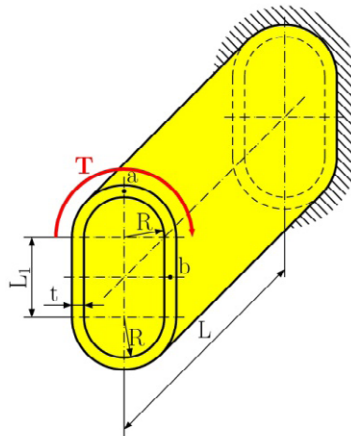


Fig. 3.55

A torque $T = 850 \text{ Nm}$ is applied to a hollow shaft with uniform wall thickness $t = 6 \text{ mm}$ shown in Fig. 3.55. Neglecting the effect of stress concentration, determine the shearing stress at points a and b. Determine the angle of twist at the end of shaft when L is 200 mm and the modulus of rigidity is $G = 77 \text{ GPa}$.

Given: $R = 30 \text{ mm}$, $t = 6 \text{ mm}$, $L_1 = 60 \text{ mm}$, $L = 200 \text{ mm}$.

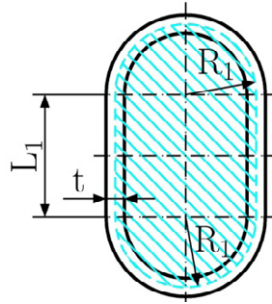
Solution

Fig. 3.56

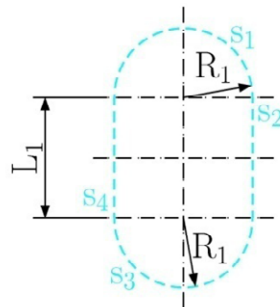


Fig. 3.57

From the definition of maximum shearing stress for thin-walled hollow shafts, we have

$$\tau_{\max} = \frac{T}{2 A t_{\min}},$$

where A is the area bounded by the centerline of wall cross-section area (Fig. 3.56 – hatching area), we have

$$A = \pi R_1^2 + 2R_1 L_1 = \pi \left(R + \frac{t}{2} \right)^2 + 2 \left(R + \frac{t}{2} \right) L_1$$

The shearing stress at point a and b is

$$\tau_a = \tau_b = \frac{T}{2 A t_{\min}} = \frac{850000 \text{ Nmm}}{2 \times 6 \text{ mm} \times 7381,19 \text{ mm}^2} = 9.6 \text{ MPa}$$

The angle of twist of a thin-walled shaft of length L and modulus of rigidity G is defined

$$\varphi = \frac{T L}{G J}$$

where the moment of inertia is $J = \frac{4A^2}{\int_s \frac{ds}{dt}}$

Integral $\int_s \frac{ds}{dt}$ is computed along the centerline of the wall section and we get

$$\int_s \frac{ds}{dt} = \frac{s_1}{t} + \frac{s_2}{t} + \frac{s_3}{t} + \frac{s_4}{t} = \frac{\pi \cdot 33 \text{ mm}}{6 \text{ mm}} + \frac{60 \text{ mm}}{6 \text{ mm}} + \frac{\pi \cdot 33 \text{ mm}}{6 \text{ mm}} + \frac{60 \text{ mm}}{6 \text{ mm}} = 54.5575$$

$$J = \frac{4A^2}{\int_s \frac{ds}{dt}} = \frac{4 \times (7381.19 \text{ mm}^2)^2}{54.5575} = 3994460.65 \text{ mm}^4$$

Angle of twist at the end of the shaft is given by the following

$$\varphi = \frac{T L}{G J} = \frac{850000 \text{ Nmm} \times 200 \text{ mm}}{77 \times 10^3 \text{ MPa} \times 3994460.65 \text{ mm}^4} = 5.527 \times 10^{-4} \text{ rad} = 0.032^\circ$$

© 2013 Accenture. All rights reserved.

be > your degree

Bring your talent and passion to a global organization at the forefront of business, technology and innovation. Discover how great you can be.

Visit accenture.com/bookboon

Be greater than.
consulting | technology | outsourcing

accenture
High performance. Delivered.

Unsolved problems

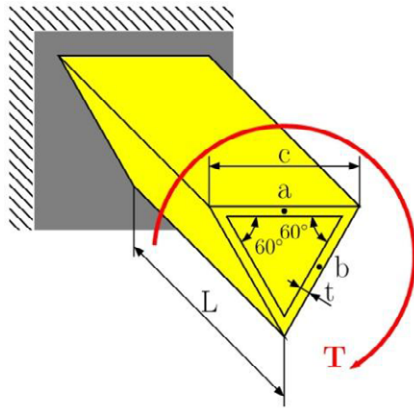


Fig. 3.58

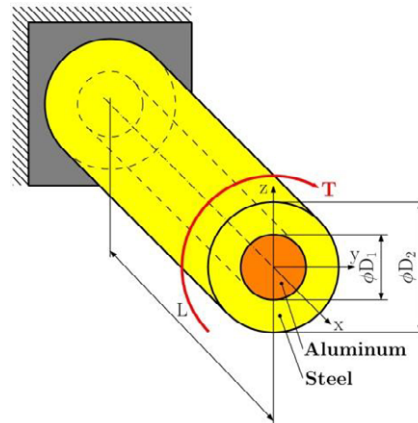


Fig. 3.59

Problem 3.8

A torque $T = 750 \text{ Nm}$ is applied to the hollow shaft shown in the Fig. 3.58 that has a uniform wall thickness of $t = 8 \text{ mm}$. Neglecting the effect of stress concentration, determine the shearing stress at points a and b.

$$[\tau_a = \tau_b = 16.1 \text{ MPa}]$$

Problem 3.9

The composite shaft in the Fig. 3.59 is twisted by applying a torque T at its end. Knowing that the maximum shearing stress in steel is 150 MPa , determine the corresponding maximum shearing stress in the aluminum core. Use $G = 77 \text{ GPa}$ for steel and $G = 27 \text{ GPa}$ for aluminum.

$$[\tau_{\text{max aluminum}} = 39.44 \text{ MPa}, T = 10.31 \text{ kNm}]$$

Problem 3.10

A statically indeterminate circular shaft BH consists of length L and diameter D (portion CH) and length L with diameter $2D$ (portion BC). The shaft is attached by fixed supports at both ends, and a torque T is applied at point C (see Fig. 3.60). Determine the maximum shearing stress in portion BC and CH, and reaction at the support in point H.

$$\left[T_H = \frac{T}{17}, \tau_{\text{max BC}} = \frac{32 T}{17 \pi D^3}, \tau_{\text{max CH}} = \frac{16 T}{17 \pi D^3} \right]$$

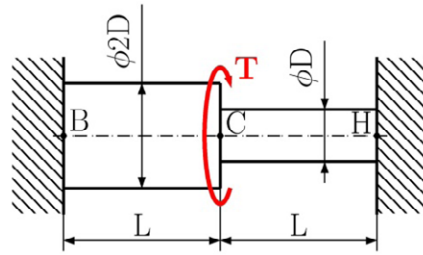


Fig. 3.60

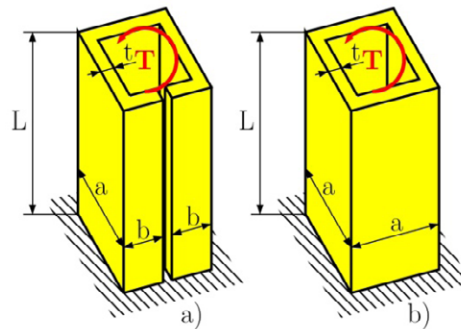


Fig. 3.61

Problem 3.11

Using $\tau_{all} = 150 \text{ MPa}$, determine the largest torque T that may be applied to each of the steel bars and to the steel tube shown in Fig. 3.61. Given is $a = 50 \text{ mm}$, $b = 24 \text{ mm}$, $t = 8 \text{ mm}$ and $L = 200 \text{ mm}$.

[(a) $T = 531.2 \text{ Nm}$, (b) $T = 4233.6 \text{ Nm}$]

Problem 3.12

A 1.25 m long angle iron with L cross-section (shown in Fig. 3.62). Knowing that the allowable shearing stress $\tau_{all} = 60 \text{ MPa}$ and modulus of rigidity $G = 77 \text{ GPa}$ and ignoring the effects of stress concentration, (a) determine the largest magnitude of torque T that may be applied, (b) the corresponding angle of twist at the free ends. The dimensions are $h = 50 \text{ mm}$, $b = 25 \text{ mm}$, $t = 5 \text{ mm}$ and $L = 200 \text{ mm}$.

[(a) $T = 35 \text{ kNm}$, (b) $j = 31.2 \text{ rad}$]

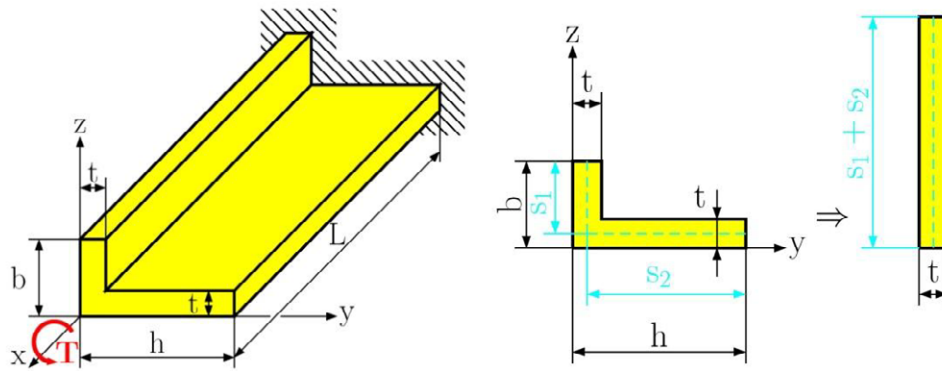


Fig. 3.62

The Wake


the only emission we want to leave behind

Low-speed Engines Medium-speed Engines Turbochargers Propellers Propulsion Packages PrimeServ

The design of eco-friendly marine power and propulsion solutions is crucial for MAN Diesel & Turbo. Power competencies are offered with the world's largest engine programme – having outputs spanning from 450 to 87,220 kW per engine. Get up front! Find out more at www.mandieselturbo.com

Engineering the Future – since 1758.

MAN Diesel & Turbo



 [Click on the ad to read more](#)

Please find the second part of this book by downloading
"Introduction to Mechanics of Materials: Part II"

Appendix

A.1 Centroid and first moment of areas

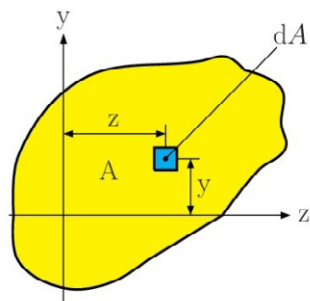


Fig. A.1

Consider an area A located in the zy plane (Fig. A.1). The first moment of area with respect to the z axis is defined by the integral

$$Q_z = \int_A y \, dA \quad (\text{A.1})$$

Similarly, the first moment of area A with respect to the y axis is

$$Q_y = \int_A z \, dA \quad (\text{A.2})$$

If we use SI units are used, the first moment of Q_z and Q_y are expressed in m^3 or mm^3 .

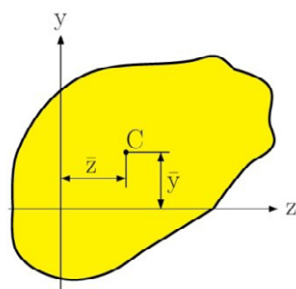


Fig. A.2

The centroid of the area A is defined at point C of coordinates \bar{y} and \bar{z} (Fig. A.2), which satisfies the relation

$$\bar{y} = \frac{\int_A y \, dA}{A}$$

$$\bar{z} = \frac{\int z \, dA}{A} \tag{A.3}$$

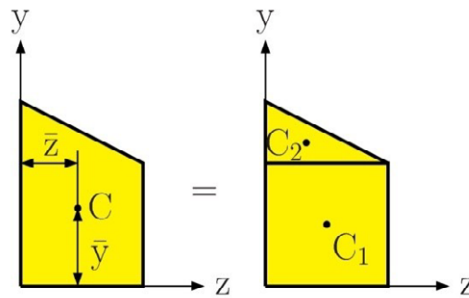


Fig. A.3

When an area possesses an axis of symmetry, the first moment of the area with respect to that axis is zero.

Considering an area A , such as the trapezoidal area shown in Fig. A.3, we may divide the area into simple geometric shapes. The solution of the first moment Q_z of the area with respect to the z axis can be divided into components A_1, A_2 , and we can write

$$Q_z = \int_A y \, dA = \int_{A_1} y \, dA + \int_{A_2} y \, dA = \sum \bar{y}_i A_i \tag{A.4}$$

Solving the centroid for composite area, we write

$$\bar{y} = \frac{\sum A_i \bar{y}_i}{\sum A_i} \qquad \bar{z} = \frac{\sum A_i \bar{z}_i}{\sum A_i} \tag{A.5}$$

Example A.01

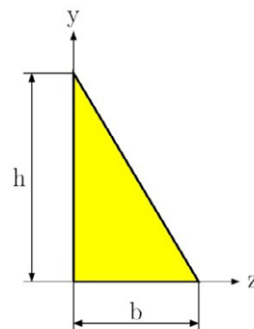
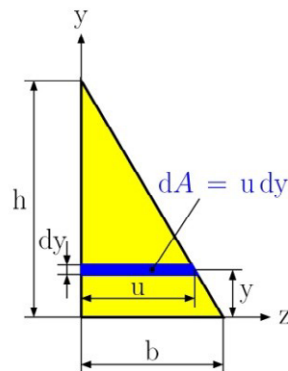


Fig. A.4

For the triangular area in Fig. A.4, determine (a) the first moment Q_z of the area with respect to the z axis, (b) the \bar{y} ordinate of the centroid of the area.

Solution**(a) First moment Q_z** **Fig. A.5**

We selected an element area in Fig. A.5 with a horizontal length u and thickness dy . From the similarity in triangles, we have

$$\frac{u}{b} = \frac{h-y}{h} \quad u = b \frac{h-y}{h}$$

and

$$dA = u \, dy = b \frac{h-y}{h} \, dy$$

using Eq. (A.1) the first moment is

$$Q_z = \int_A y \, dA = \int_0^h y b \frac{h-y}{h} \, dy = \frac{b}{h} \int_0^h (hy - y^2) \, dy$$

$$Q_z = \frac{b}{h} \left[h \frac{y^2}{2} - \frac{y^3}{3} \right] = \frac{1}{6} bh^2$$

(b) Ordinate of the centroid

Recalling the first Eq. (A.4) and observing that $A = \frac{1}{2}bh$, we get

$$Q_z = A\bar{y} \Rightarrow \frac{1}{6}bh^2 = \frac{1}{2}bh^2\bar{y} \Rightarrow \bar{y} = \frac{1}{3}h$$

A.2 Second moment, moment of areas

Consider again an area A located in the zy plane (Fig. A.1) and the element of area dA of coordinate y and z . The *second moment*, or *moment of inertia*, of area A with respect to the z -axis is defined as

$$I_z = \int_A y^2 dA \tag{A.6}$$

Example A.02

Locate the centroid C of the area A shown in Fig. A.6

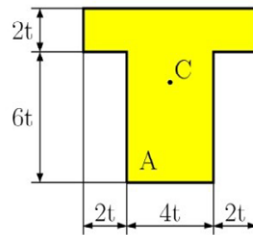


Fig. A.6

SMS from your computer

...Sync'd with your Android phone & number

FREE
30 days trial!

Go to

BrowserTexting.com

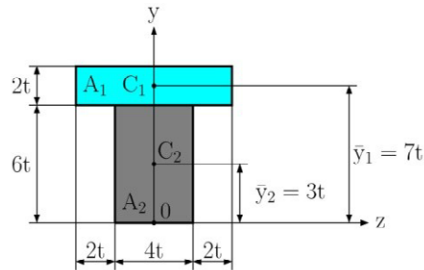
and start texting from your computer!

BrowserTexting



Solution

Selecting the coordinate system shown in Fig. A.7, we note that centroid C must be located on the y axis, since this axis is the axis of symmetry than $\bar{z} = 0$.

**Fig. A.7**

Dividing A into its component parts A_1 and A_2 , determine the \bar{y} ordinate of the centroid, using Eq. (A.5)

$$\bar{y} = \frac{\sum_i A_i \bar{y}_i}{\sum_i A_i} = \frac{\sum_{i=1}^2 A_i \bar{y}_i}{\sum_{i=1}^2 A_i} = \frac{A_1 \bar{y}_1 + A_2 \bar{y}_2}{A_1 + A_2}$$

$$\bar{y} = \frac{A_1 \bar{y}_1 + A_2 \bar{y}_2}{A_1 + A_2} = \frac{(2t \times 8t) \times 7t + (4t \times 6t) \times 3t}{2t \times 8t + 4t \times 6t} = \frac{184t^3}{40t^2} = 4.6t$$

Similarly, the *second moment*, or *moment of inertia*, of area A with respect to the y axis is

$$I_y = \int_A z^2 \, dA. \quad (\text{A.7})$$

We now define the *polar moment of inertia* of area A with respect to point O (Fig. A.8) as the integral

$$J_o = \int_A \rho^2 \, dA, \quad (\text{A.8})$$

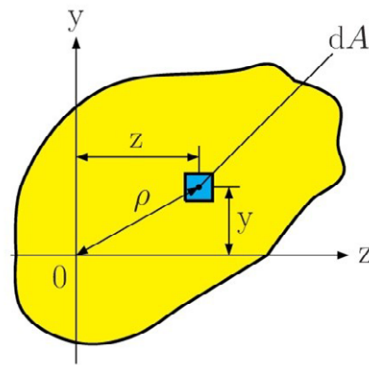


Fig. A.8

where ρ is the distance from O to the element dA . If we use SI units, the moments of inertia are expressed in m^4 or mm^4 .

An important relation may be established between the polar moment of inertia J_o of a given area and the moment of inertia I_z and I_y of the same area. Noting that $\rho^2 = y^2 + z^2$, we write

$$J_o = \int_A \rho^2 dA = \int_A (y^2 + z^2) dA = \int_A y^2 dA + \int_A z^2 dA$$

or

$$J_o = I_z + I_y \quad (\text{A.9})$$

The *radius of gyration* of area A with respect to the z axis is defined as the quantity r_z , that satisfies the relation

$$I_z = r_z^2 A \Rightarrow r_z = \sqrt{\frac{I_z}{A}} \quad (\text{A.10})$$

In a similar way, we defined the radius of gyration with respect to the y axis and origin O. We then have

$$I_y = r_y^2 A \Rightarrow r_y = \sqrt{\frac{I_y}{A}} \quad (\text{A.11})$$

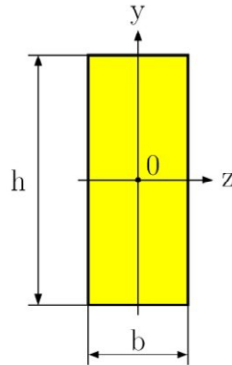
$$J_o = r_o^2 A \Rightarrow r_o = \sqrt{\frac{J_o}{A}} \quad (\text{A.12})$$

Substituting for J_o , I_y and I_z in terms of its corresponding radii of gyration in Eg. (A.9), we observe that

$$r_o^2 = r_z^2 + r_y^2 \quad (\text{A.13})$$

Example A.03

For the rectangular area in Fig. A.9, determine (a) the moment of inertia I_z of the area with respect to the centroidal axis, (b) the corresponding radius of gyration r_z .

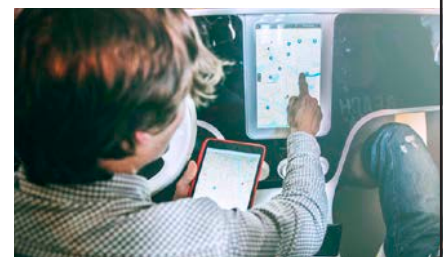
**Fig. A.9****Solution**

(a) **Moment of inertia I_z .** We select, as an element area, a horizontal strip with length b and thickness dy (see Fig. A.10). For the solution we use Eq. (A.6), where $dA = b dy$, we have

**YOUR WORK AT TOMTOM WILL
BE TOUCHED BY MILLIONS.
AROUND THE WORLD. EVERYDAY.**

Join us now on www.TomTom.jobs

follow us on **LinkedIn**



#ACHIEVEMORE

TOMTOM 

$$I_z = \int_A y^2 \, dA = \int_{-h/2}^{+h/2} y^2 (b \, dy) = b \int_{-h/2}^{+h/2} y^2 \, dy = \frac{b}{3} [y^3]_{-h/2}^{+h/2}$$

$$I_z = \frac{b}{3} \left(\frac{h^3}{8} + \frac{h^3}{8} \right) \Rightarrow I_z = \frac{1}{12} b h^3$$

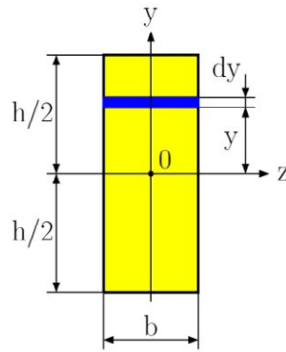


Fig. A.10

(b) **Radius of gyration r_z .** From Eq. (A.10), we have

$$r_z = \sqrt{\frac{I_z}{A}} = \sqrt{\frac{\frac{1}{12} b h^3}{b h}} = \sqrt{\frac{h^2}{12}} \Rightarrow r_z = \frac{h}{\sqrt{12}}$$

Example A.04

For the circular cross-section in Fig. A.11. Determine (a) the polar moment of inertia J_O , (b) the moment of inertia I_z and I_y .

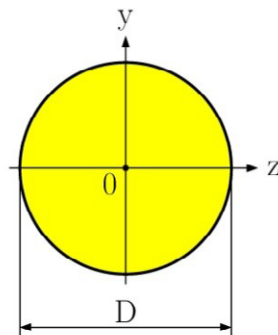


Fig. A.11

Solution

(a) **Polar moment of Inertia.** We select, as an element of area, a ring of radius ρ and thickness $d\rho$ (Fig. A.12). Using Eq. (A.8), where $dA = 2\pi\rho d\rho$, we have

$$J_o = \int_A \rho^2 dA = \int_0^{D/2} \rho^2 2\pi\rho d\rho = 2\pi \int_0^{D/2} \rho^3 d\rho,$$

$$J_o = \frac{\pi D^4}{32}.$$

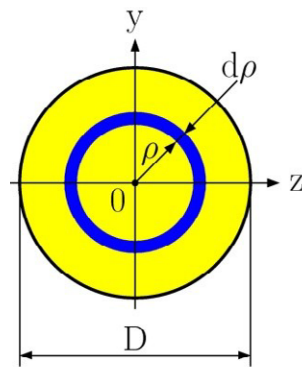


Fig. A.12

(b) **Moment of Inertia.** Because of the symmetry of a circular area $I_z = I_y$. Recalling Eq. (A.9), we can write

$$J_o = I_z + I_y = 2I_z \quad \Rightarrow \quad I_z = \frac{J_o}{2} = \frac{\pi D^4}{32} \cdot \frac{1}{2}$$

$$I_z = I_y = \frac{\pi D^4}{64}.$$

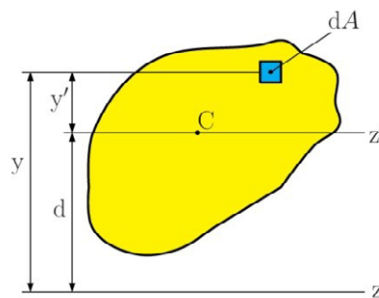
A.3 Parallel axis theorem

Fig. A.13

Considering the moment of inertia I_z of an area A with respect to an arbitrary z axis (Fig. A.13). Let us now draw the *centroidal* z' axis, i.e., the axis parallel to the z axis which passes through the area's centroid C . Denoting the distance between the element dA and axis passes through the centroid C by y' , we write $y = y' + d$. Substituting for y in Eq. (A.6), we write

$$\begin{aligned}
 I_z &= \int_A y^2 \, dA = \int_A (y' + d)^2 \, dA, \\
 I_z &= \int_A y'^2 \, dA + 2d \int_A y' \, dA + d^2 \int_A dA, \\
 I_z &= \bar{I}_{z'} + Q_{z'} + Ad^2
 \end{aligned}
 \tag{A.14}$$

where $\bar{I}_{z'}$ is the area's moment of inertia with respect to the centroidal z' axis and $Q_{z'}$ is the first moment of the area with respect to the z' axis, which is equal to zero since the centroid C of the area is located on that axis. Finally, from Eq. (A.14) we have

$$I_z = \bar{I}_{z'} + Ad^2 \tag{A.15}$$



Brain power

By 2020, wind could provide one-tenth of our planet's electricity needs. Already today, SKF's innovative know-how is crucial to running a large proportion of the world's wind turbines.

Up to 25 % of the generating costs relate to maintenance. These can be reduced dramatically thanks to our systems for on-line condition monitoring and automatic lubrication. We help make it more economical to create cleaner, cheaper energy out of thin air.

By sharing our experience, expertise, and creativity, industries can boost performance beyond expectations. Therefore we need the best employees who can meet this challenge!

The Power of Knowledge Engineering

Plug into The Power of Knowledge Engineering.
Visit us at www.skf.com/knowledge

SKF

A similar formula may be derived, which relates the polar moment of inertia J_o of an area to an arbitrary point O and polar moment of inertia J_C of the same area with respect to its centroid C . Denoting the distance between O and C by d , we write

$$J_o = J_C + Ad^2 \quad (\text{A.16})$$

Example A.05

Determine the moment of inertia I_z of the area shown in Fig. A.14 with respect to the centroidal z axis.

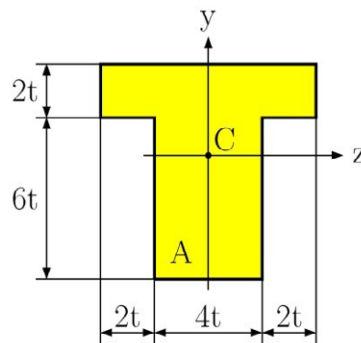


Fig. A.14

Solution

The first step of the solution is to locate the centroid C of the area. However, this has already been done in Example A.02 for a given area A .

We divide the area A into two rectangular areas A_1 and A_2 (Fig. A.15) and compute the moment of inertia of each area with respect to the z axis. Moment of inertia of the areas are

$$I_z = I_{z1} + I_{z2},$$

where I_{z1} is the moment of inertia of A_1 with respect to the z axis. For the solution, we use the parallel-axis theorem (Eq. A.15), and write

$$I_{z1} = \bar{I}_{z'} + A_1 d_1^2 = \frac{1}{12} b_1 h_1^3 + b_1 h_1 d_1^2$$

$$I_{z1} = \frac{1}{12} \times 8t \times (2t)^3 + 8t \times 2t \times (7t - 4 \cdot 6t)^2$$

$$I_{z1} = 97.5 t^4$$

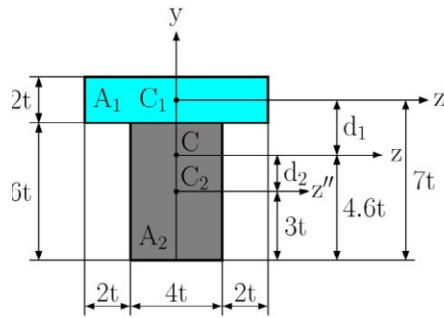


Fig. A.15

In a similarly way, we find the moment of inertia I_{z2} of A_2 with respect to the z axis and write

$$I_{z2} = \bar{I}_{z''} + A_2 d_2^2 = \frac{1}{12} b_2 h_2^3 + b_2 h_2 d_2^2$$

$$I_{z2} = \frac{1}{12} \times 4t \times (6t)^3 + 4t \times 6t \times (4.6t - 3t)^2$$

$$I_{z1} = 133.4 t^4$$

The moment of inertia I_z of the area shown in Fig. A.14 with respect to the centroidal z axis is

$$I_z = I_{z1} + I_{z2} = 97.5t^4 + 133.4t^4 = 230.9t^4.$$

Example A.06

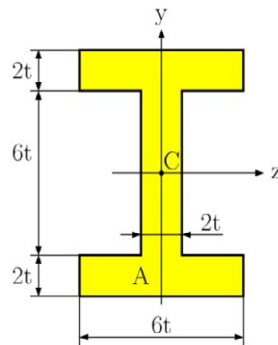


Fig. A.16

Determine the moment of inertia I_z of the area shown in Fig. A.14 with respect to the centroidal z axis and the moment of inertia I_y of the area with respect to the centroidal y axis.

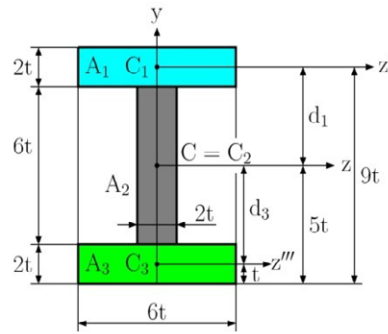


Fig. A.17

Solution

The first step of the solution is to locate the centroid C of the area. This area has two axis of symmetry, the location of the centroid C is in the intersection of the axes of symmetry.

> Apply now

REDEFINE YOUR FUTURE
AXA GLOBAL GRADUATE PROGRAM 2015

redefining / standards **AXA**

agence.cdg © Photonistop



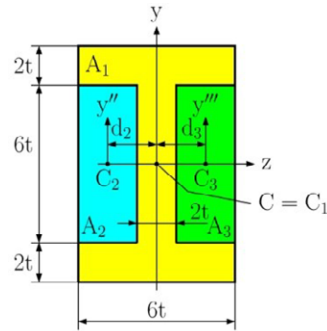


Fig. A.18

We divide the area A into three rectangular areas A_1 , A_2 and A_3 . The first way we can divide area A can be seen in Fig. A.17, a second way can be seen in Fig. A.18.

Solution the division of area A by Fig. A.17 (the first way) the moment of inertia I_z is

$$I_z = I_{z1} + I_{z2} + I_{z3},$$

where

$$I_{z1} = \bar{I}_z + A_1 d_1^2 = \frac{1}{12} b_1 h_1^3 + b_1 h_1 d_1^2 = \dots = 196t^4,$$

$$I_{z2} = \bar{I}_z + A_2 d_2^2 = \frac{1}{12} b_2 h_2^3 + b_2 h_2 d_2^2 = \dots = 36t^4,$$

$$I_{z3} = \bar{I}_z + A_3 d_3^2 = \frac{1}{12} b_3 h_3^3 + b_3 h_3 d_3^2 = \dots = 196t^4.$$

Resulting in

$$I_z = I_{z1} + I_{z2} + I_{z3} = 196t^4 + 36t^4 + 196t^4 = 428t^4.$$

For the moment of inertia I_y we have

$$I_y = I_{y1} + I_{y2} + I_{y3},$$

where

$$I_{y1} = \bar{I}_y = \frac{1}{12} h_1 b_1^3 = \frac{1}{12} \times 2t \times (6t)^3 = 36t^4,$$

$$I_{y2} = \bar{I}_y = \frac{1}{12} h_2 b_2^3 = \frac{1}{12} \times 6t \times (2t)^3 = 4t^4,$$

$$I_{y3} = \bar{I}_y = \frac{1}{12} h_3 b_3^3 = \frac{1}{12} \times 2t \times (6t)^3 = 36t^4.$$

Resulting in

$$I_y = I_{y1} + I_{y2} + I_{y3} = 36t^4 + 4t^4 + 36t^4 = 76t^4.$$

The solution for the division of area A according to Fig. A.18 (by the second way) the moment of inertia I_z is

$$I_z = I_{z1} - I_{z2} - I_{z3},$$

where

$$I_{z1} = \bar{I}_z = \frac{1}{12} b_1 h_1^3 = \frac{1}{12} \times 6t \times (10t)^3 = 500t^4,$$

$$I_{z2} = \bar{I}_z = \frac{1}{12} b_2 h_2^3 = \frac{1}{12} \times 2t \times (6t)^3 = 36t^4,$$

$$I_{z3} = \bar{I}_z = \frac{1}{12} b_3 h_3^3 = \frac{1}{12} \times 2t \times (6t)^3 = 36t^4.$$

Resulting in

$$I_z = I_{z1} - I_{z2} - I_{z3} = 500t^4 - 36t^4 - 36t^4 = 428t^4.$$

For the moment of inertia I_y we have

$$I_y = I_{y1} - I_{y2} - I_{y3},$$

where

$$I_{y1} = \bar{I}_y = \frac{1}{12} h_1 b_1^3 = \frac{1}{12} \times 10t \times (6t)^3 = 180t^4,$$

$$I_{y2} = \bar{I}_y = \frac{1}{12} h_2 b_2^3 + h_2 b_2 d_2^2 = \frac{1}{12} \times 6t \times (2t)^3 + 6t \times 2t \times (2t)^2 = 52t^4,$$

$$I_{y3} = \bar{I}_y = \frac{1}{12} h_3 b_3^3 + h_3 b_3 d_3^2 = \frac{1}{12} \times 6t \times (2t)^3 + 6t \times 2t \times (2t)^2 = 52t^4.$$

Resulting in

$$I_y = I_{y1} - I_{y2} - I_{y3} = 180t^4 - 52t^4 - 52t^4 = 76t^4.$$

Example A.07

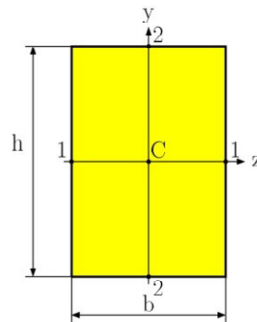


Fig. A.19

LIGS University

based in Hawaii, USA

is currently enrolling in the
Interactive Online **BBA, MBA, MSc,**
DBA and PhD programs:

- ▶ enroll **by October 31st, 2014** and
- ▶ **save up to 11%** on the tuition!
- ▶ pay in 10 installments / 2 years
- ▶ Interactive **Online** education
- ▶ visit www.ligsuniversity.com to
find out more!

Note: LIGS University is not accredited by any nationally recognized accrediting agency listed by the US Secretary of Education. More info [here](#).



Click on the ad to read more

In order to solve the torsion of a rectangular cross-section in Fig. A.19, we defined (See S.P. Timoshenko and J.N. Goodier, Theory of Elasticity, 3d ed. McGraw-Hill, New York, 1969, sec. 109) the following parameters for $b > h$:

$$J = \gamma b^3 h, \quad (\text{A.17})$$

$$S_1 = \alpha b^2 h, \quad (\text{A.18})$$

$$S_2 = \beta b h^2, \quad (\text{A.19})$$

where parameters α , β and γ are in Tab.A.1.

The shearing stresses at point 1 and 2 are defined as

$$\tau_1 = \tau_{\max} = \frac{T}{S_1}, \quad \tau_2 = \frac{T}{S_2}, \quad (\text{A.20})$$

where T is the applied torque.

Tab.A.1

h/b	1	1.2	1.5	2	3	5	10	>10
α	0.208	0.219	0.231	0.246	0.267	0.291	0.313	1/3
β	0.208	0.196	0.180	0.155	0.118	0.078	0.042	0
γ	0.1404	0.166	0.196	0.229	0.263	0.291	0.313	1/3

A.4 Product of Inertia, Principal Axes

Definition of product of inertia is

$$I_{yz} = \int_A y z \, dA \quad (\text{A.20a})$$

in which each element of area dA is multiplied by the product of its coordinates and integration is extended over the entire area A of a plane figure. If a cross-section area has an axis of symmetry which is taken for the y or z axis (Fig. A.19), the product of inertia is equal to zero. In the general case, for any point of any cross-section area, we can always find two perpendicular axes such that the product of inertia for these vanishes. If this quantity becomes zero, the axes in these directions are called the *principal axes*. Usually the centroid is taken as the origin of coordinates and the corresponding principal axes are then called the *centroidal principal axes*.

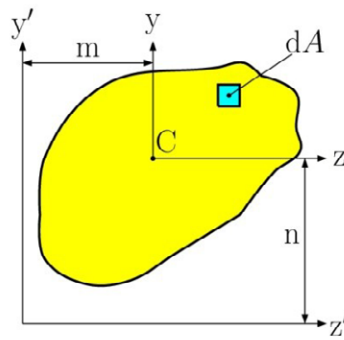


Fig. A.19a

If the product of inertia of a cross-section area is known for axes y and z (Fig. A.19a) through the centroid, the product of inertia for parallel axes y' and z' can be found from the equation

$$I_{y'z'} = I_{yz} + Amn. \tag{A.20b}$$

The coordinates of an element dA for the new axes are

$$y' = y + n; \quad z' = z + m.$$

Hence,

$$I_{y'z'} = \int_A y'z' dA = \int_A (y + n)(z + m) dA = \int_A yz dA + \int_A mn dA + \int_A ym dA + \int_A nz dA.$$

The last two integrals vanish because C is the centroid so that the equation reduces to (A.20b).

A.5 Strain energy for simple loads

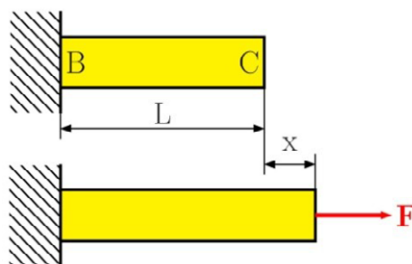


Fig. A.20

Consider a rod BC of length L and uniform cross-section area A , attached at B to a fixed support. The rod is subjected to a slowly increasing axial load F at C (Fig. A.20). The work done by the load F as it is slowly applied to the rod must result in the increase of some energy associated with the deformation of the rod. This energy is referred to as the *strain energy* of the rod. Which is defined by

$$\text{Strain energy} = U = \int_0^x F \, dx \quad (\text{A.21})$$

Dividing the strain energy U by the volume $V = A L$ of the rod (Fig. A.20) and using Eq. (A.21), we have

$$\frac{U}{V} = \int_0^{\varepsilon} \frac{F}{A L} \, dx \quad (\text{A.22})$$

Recalling that F/A represents the normal stress σ_x in the rod, and x/L represents the normal strain ε_x , we write

$$\frac{U}{V} = \int_0^{\varepsilon} \sigma_x \, d\varepsilon_x \quad (\text{A.23})$$

The strain energy per unit volume, U/V , is referred to as the strain-energy density and will be denoted by the letter u . We therefore have

TURN TO THE EXPERTS FOR SUBSCRIPTION CONSULTANCY

Subscribe is one of the leading companies in Europe when it comes to innovation and business development within subscription businesses.

We innovate new subscription business models or improve existing ones. We do business reviews of existing subscription businesses and we develop acquisition and retention strategies.

Learn more at [linkedin.com/company/subscribe](https://www.linkedin.com/company/subscribe) or contact
Managing Director Morten Suhr Hansen at mha@subscribe.dk

SUBSCRIB✓**BE** - to the future

$$u = \int_0^{\varepsilon} \sigma_x \, d\varepsilon_x \quad (\text{A.24})$$

A.5.1 Elastic strain energy for normal stresses

In a machine part with non-uniform stress distribution, the strain energy density u can be defined by considering the strain energy of a small element of the material with the volume ΔV . writing

$$u = \lim_{\Delta V \rightarrow 0} \frac{\Delta U}{\Delta V} \text{ or } u = \frac{dU}{dV}. \quad (\text{A.25})$$

for the value of σ_x within the proportional limit, we may set $\sigma_x = E \varepsilon_x$ in Eq. (A.24) and write

$$u = \frac{1}{2} E \varepsilon_x^2 = \frac{1}{2} \sigma_x \varepsilon_x = \frac{\sigma_x^2}{2E}. \quad (\text{A.26})$$

The value of strain energy U of the body subject to uniaxial normal stresses can be obtained by substituting Eq. (A.26) into Eq. (A.25), to get

$$U = \int \frac{\sigma_x^2}{2E} \, dV. \quad (\text{A.27})$$

Elastic strain energy under axial loading

When a rod is acted on by centric axial loading, the normal stresses are $\sigma_x = N/A$ from Sec. 2.2. Substituting for σ_x into Eq. (A.27), we have

$$U = \int \frac{N^2}{2EA^2} \, dV \text{ or, setting } dV = A \, dV, \quad U = \int_0^L \frac{N^2}{2EA} \, dV \quad (\text{A.28})$$

If the rod has a uniform cross-section and is acted on by a constant axial force F , we then have

$$U = \frac{N^2 L}{2EA} \quad (\text{A.29})$$

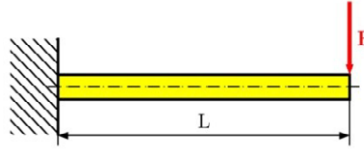
Elastic strain energy in Bending

The normal stresses for pure bending (neglecting the effects of shear) is $\sigma_x = My/I$ from Sec. 4. Substituting for σ_x into Eq. (A.27), we have

$$U = \int \frac{\sigma_x^2}{2E} \, dV = \int \frac{M^2 y^2}{2EI^2} \, dV \quad (\text{A.30})$$

Setting $dV = dA \, dx$, where dA represents an element of cross-sectional area, we have

$$U = \int_0^L \frac{M^2}{2EI^2} \left(\int y^2 dA \right) dx = \int_0^L \frac{M^2}{2EI} dx \quad (\text{A.31})$$

Example A.08**Fig. A.21**

Determine the strain energy of the prismatic cantilever beam in Fig. A.21, taking into account the effects of normal stresses only.

Solution

The bending moment at a distance x from the free end is $M = -F x$. Substituting this expression into Eq. (A.31), we can write

$$U = \int_0^L \frac{M^2}{2EI} dx = \int_0^L \frac{(F x)^2}{2EI} dx = \frac{F^2 L^3}{6EI}$$

A.5.2 Elastic strain energy for shearing stresses

When a material is acted on by plane shearing stresses τ_{xy} the strain-energy density at a given point can be expressed as

$$u = \int_0^{\gamma} \tau_{xy} d\gamma_{xy}, \quad (\text{A.32})$$

where γ_{xy} is the shearing strain corresponding to τ_{xy} . For the value of τ_{xy} within the proportional limit, we have $\tau_{xy} = G \gamma_{xy}$, and write

$$u = \frac{1}{2} G \gamma_{xy}^2 = \frac{1}{2} \tau_{xy} \gamma_{xy} = \frac{\tau_{xy}^2}{2G}. \quad (\text{A.33})$$

Substituting Eq. (A.33) into Eq. (A.25), we have

$$U = \int \frac{\tau_{xy}^2}{2G} dV. \quad (\text{A.34})$$

Elastic strain energy in Torsion

The shearing stresses for pure torsion are $\tau_{xy} = T\rho / J$ from Sec. 3. Substituting for τ_{xy} into Eq. (A.27), we have

$$U = \int \frac{\tau_{xy}^2}{2G} dV = \int \frac{T^2 \tilde{r}^2}{2GEJ^2} dV \quad (\text{A.35})$$

Setting $dV = dA dx$, where dA represents an element of the cross-sectional area, we have

$$U = \int_0^L \frac{T^2}{2GJ^2} \left(\int \rho^2 dA \right) dx = \int_0^L \frac{T^2}{2GJ} dx \quad (\text{A.36})$$

In the case of a shaft of uniform cross-section acted on by a constant torque T , we have

$$\overline{\frac{T^2}{2G}} \quad (\text{A.37})$$

Elastic strain energy in transversal loading

If the internal shear at section x is V , then the shear stress acting on the volume element, having a length of dx and an area of dA , is $\tau = VQ / It$ from Sec. 4. Substituting for τ into Eq. (A.27), we have

“I studied English for 16 years but...
...I finally learned to speak it in just six lessons”
Jane, Chinese architect

ENGLISH OUT THERE

Click to hear me talking before and after my unique course download

$$U = \int_V \frac{\tau^2}{2G} dV = \int_V \frac{1}{2G} \left(\frac{V Q}{I t} \right)^2 dA dx = \int_0^L \frac{V^2}{2GI^2} \left(\int_A \frac{Q^2}{t^2} dA \right) dx \quad (\text{A.38})$$

The integral in parentheses is evaluated over the beam's cross-sectional area. To simplify this expression we define the form factor for shear

$$f_s = \frac{A}{I^2} \int_A \frac{Q^2}{t^2} dA \quad (\text{A.39})$$

Substituting Eq. (A.39) into Eq. (A.38), we have

$$U = \int_0^L f_s \frac{V^2}{2GA} dx \quad (\text{A.40})$$

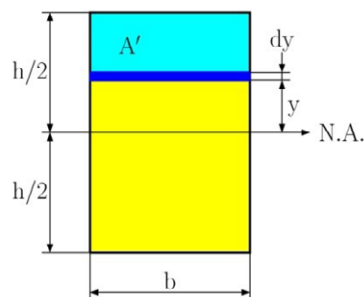


Fig. A.22

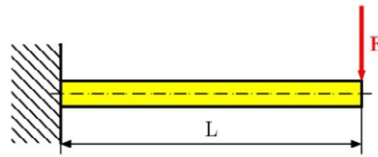
The form factor defined by Eq. (A.39) is a dimensionless number that is unique for each specific cross-section area. For example, if the beam has a rectangular cross-section with a width b and height h , as in Fig. A.22, then

$$t = b, \quad A = b h, \quad I = \frac{1}{12} b h^3$$

$$Q = \bar{y}' A' = \left(y + \frac{\frac{h}{2} - y}{2} \right) b \left(\frac{h}{2} - y \right) = \frac{b}{2} \left(\frac{h^2}{4} - y^2 \right)$$

Substituting these terms into Eq. (A.39), we get

$$f_s = \frac{bh}{\left(\frac{1}{12} bh^3 \right)^2} \int_{-h/2}^{+h/2} \frac{b^2}{4b^2} \left(\frac{h^2}{4} - y^2 \right) b dy = \frac{6}{5} \quad (\text{A.41})$$

Example A.09**Fig. A.23**

Determine the strain energy in the cantilever beam due to shear if the beam has a rectangular cross-section and is subject to a load F , Fig. A.23. assume that EI and G are constant.

Solution

From the free body diagram of the arbitrary section, we have

$$V(x) = F.$$

Since the cross-section is rectangular, the form factor $f_s = \frac{6}{5}$ from Eq. (A.41) and therefore Eq. (A.40)

becomes

$$U_{shear} = \int_0^L \frac{6}{5} \frac{F^2}{2GA} dx = \frac{3 F^2 L}{5 GA}$$

Using the results of Example A.08, with $A = b h$, $I = \frac{1}{12} b h^3$, the ratio of the shear to the bending strain energy is

$$\frac{U_{shear}}{U_{bending}} = \frac{\frac{3 F^2 L}{5 GA}}{\frac{F^2 L^3}{6EI}} = \frac{3 h^2 E}{10 L^2 G}$$

Since $G = E / 2(1+n)$ and $n = 0.5$, then $E = 3G$, so

$$\frac{U_{shear}}{U_{bending}} = \frac{3 h^2 3G}{10 L^2 G} = \frac{9 h^2}{10 L^2}$$

It can be seen that the result of this ratio will increase as L decreases. However, even for short beams, where, say $L = 5 h$, the contribution due to shear strain energy is only 3.6% of the bending strain energy. For this reason, the shear strain energy stored in beams is usually neglected in engineering analysis.

References

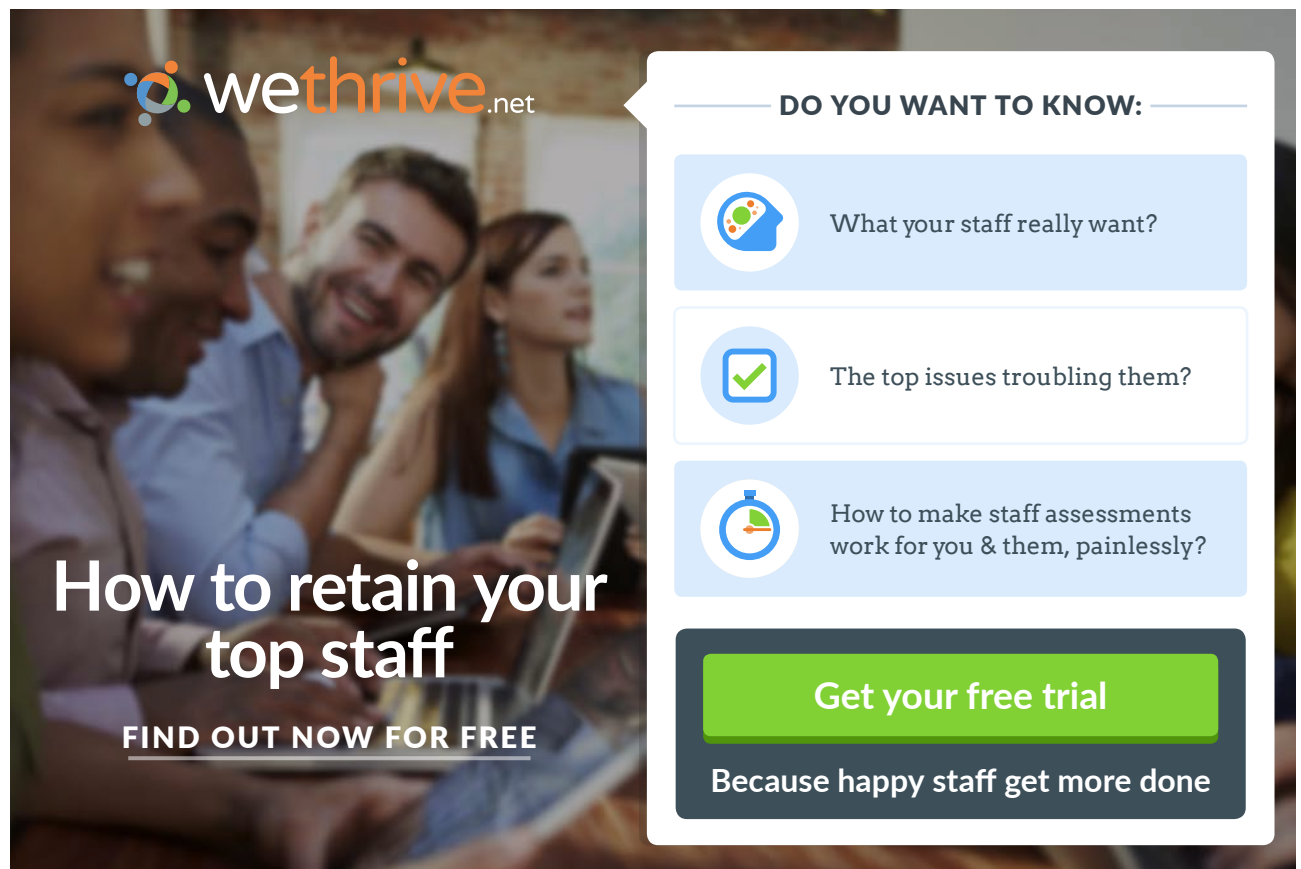
Hibbeler, R.C.: Mechanics of Materials. SI Second Edition, Prentice-Hall, Inc., 2005, ISBN 0-13-191345-X

Beer, F.P., Johnston, E.R. Jr., Dewolf, J.T., Mazurek, D.F.: Mechanics of Materials, Sixth Edition, McGraw-Hill, 2012, ISBN 978-0-07-338028-5

Frydryšek, K., Adámková, L.: Mechanics of Materials 1 (Introduction, Simple Stress and Strain, Basic of Bending), Faculty of Mechanical Engineering, VŠB - Technical University of Ostrava, Ostrava, ISBN 978-80-248-1550-3, Ostrava, 2007, Czech Republic, pp. 179

Halama, R., Adámková, L., Fojtík, F., Frydryšek, K., Šofer, M., Rojíček, J., Fusek, M.: Pružnost a pevnost, VŠB - Technical University of Ostrava, Ostrava 2012, 254 pp., [<http://mi21.vsb.cz/modul/pruznost-pevnost>] (in Czech)

Puchner, O., Kamenský, A., Syč-Milý, J., Tesař, S.: Pružnosť a pevnosť I, SVŠT Bratislava, ISBN 80-227-0227-7, 1990. (in Slovak)



wethrive.net

How to retain your top staff

FIND OUT NOW FOR FREE

DO YOU WANT TO KNOW:

- What your staff really want?
- The top issues troubling them?
- How to make staff assessments work for you & them, painlessly?

Get your free trial

Because happy staff get more done

Puchner, O., Kamenský, A., Syč-Milý, J., Tesař, S.: Pružnosť a pevnosť II, 2.edition, SVŠT Bratislava, ISBN 80-227-0169-6, 1989. (in Slovak)

Syč-Milý, J. a kol.: Pružnosť a pevnosť: Riešené príklady, Alfa, Bratislava, 1988. (in Slovak)

Timoshenko, S.: Strength of Materials, Elementary Theory and Problems, Part I, 2nd Edition, D. Van Nostrand Co., New York, NY, (1940)

Timoshenko, S.: Strength of Materials, Advanced Theory and Problems, Part II, 2nd Edition, D. Van Nostrand Co., New York, NY, (1947)

Trebuňa, F., Šimčák, F., Jurica, V.: Pružnosť a pevnosť I., 1. edition, Viena, Košice, ISBN 80-7099-477-0, 2000 (in Slovak)

Trebuňa, F., Šimčák, F., Jurica, V.: Pružnosť a pevnosť II., 1. edition, Viena, Košice, ISBN 80-7099-478-9, 2000 (in Slovak)

Trebuňa, F., Šimčák, F., Jurica, V.: Príklady a úlohy z pružnosti a pevnosti 1., 1. edition, Viena, Košice, ISBN 80-7099-593-9, 2000 (in Slovak)

Trebuňa, F., Šimčák, F., Jurica, V.: Príklady a úlohy z pružnosti a pevnosti 2., 1. edition, Technical University in Košice, Košice, ISBN 80-7099-594-7, 2001 (in Slovak)

Ralston, A., Rabinowitz, P.: First Course in Numerical Analysis, Second Edition, 1978, Republished 2001 by Dover, Mineola, N.Y.

Gibson, L.J., Ashby. M.F.: Cellular Solids, First Paperback Edition, Cambridge University Press, 1999, ISBN 0 521 499 119